



# The Vacuum System of the KATRIN Experiment

Joachim Wolf

Institute of Experimental Nuclear Physics

Grenoble, 02.12.2014

- 
- **KATRIN Experiment**
  - **Tritium Source**
  - **Pumping and Transport Section**
  - **Spectrometer and Detector Section**
  - **Spectrometer Commissioning**
  - **Conclusions / Next Steps**

# The **K**arlsruhe **T**Ritium **N**eutrino Experiment Karlsruhe Institute of Technology

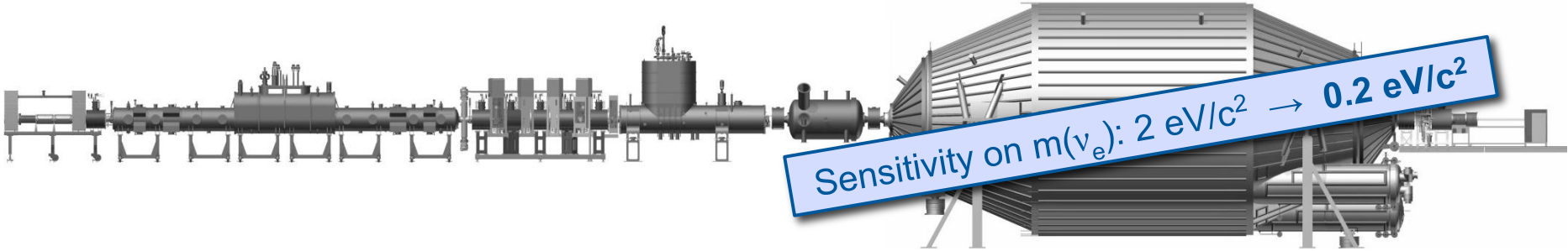

- **Goal: measure the effective neutrino mass**
- **International KATRIN collaboration:**
  - about 130 members
  - 5 countries (GER, US, CZ, RUS, ES)
  - 15 institutions



# The Karlsruhe TRITium Neutrino Experiment

KIT  
Karlsruhe Institute of Technology

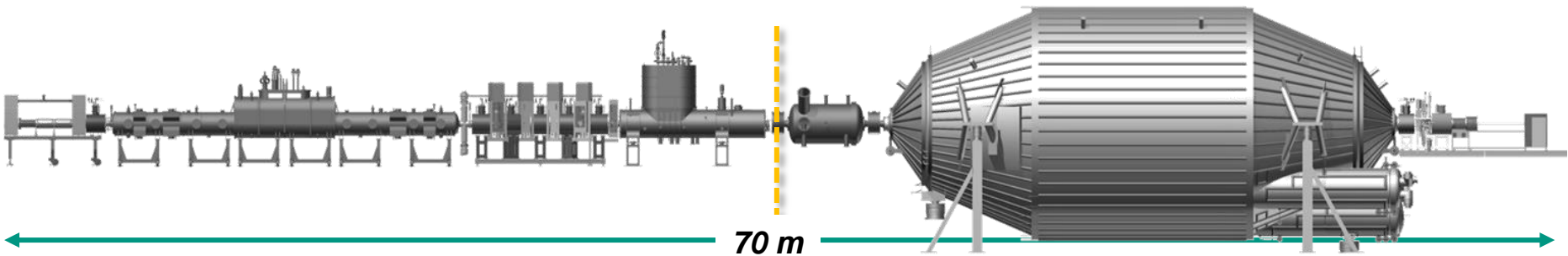

**Source & Transport Section (STS)**

**Spectrometer & Detector Section (SDS)**

ideal  
 $\beta$ -emitter

**$^3\text{H}$ : super-allowed**

$E_0$	<b>18.6 keV</b>
$t_{1/2}$	<b>12.3 y</b>

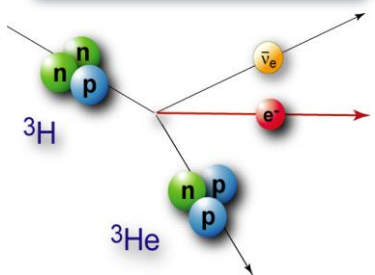
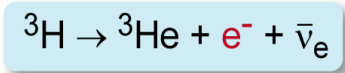

most sensitive method

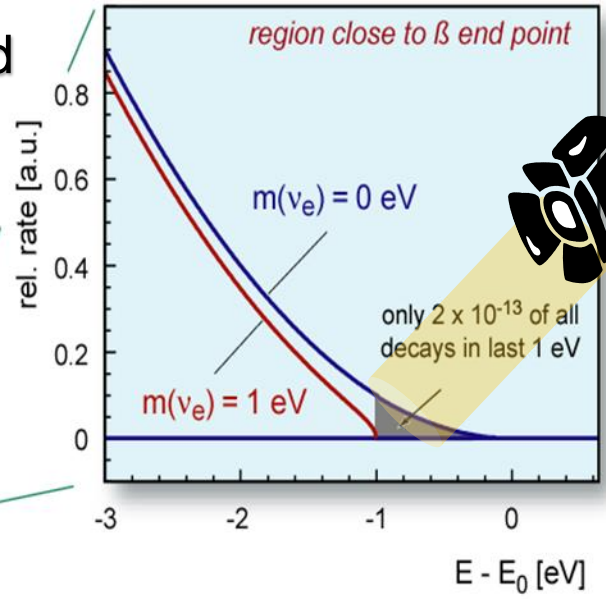
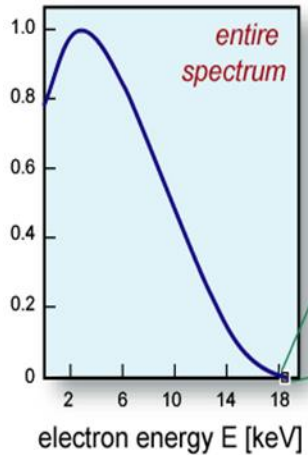

*G. Drexlin, V. Hannen, S. Mertens, C. Weinheimer, Current Direct Neutrino Mass Experiments (Review) Advances In High Energy Physics (2013) 293986*

# The MAC-E Filter

A. Picard et al., NIM B 63 (1992)

Magnetic Adiabatic Collimation  
with Electrostatic Filter

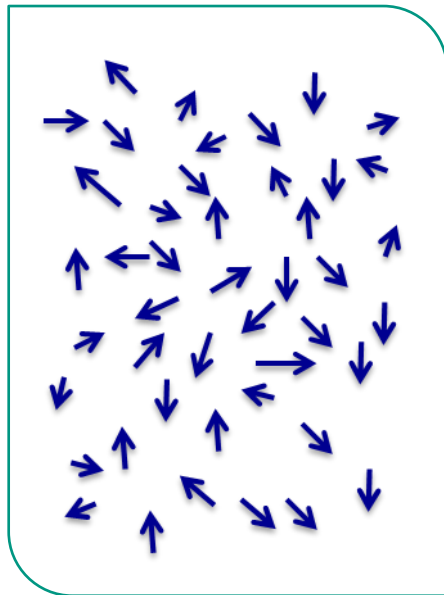
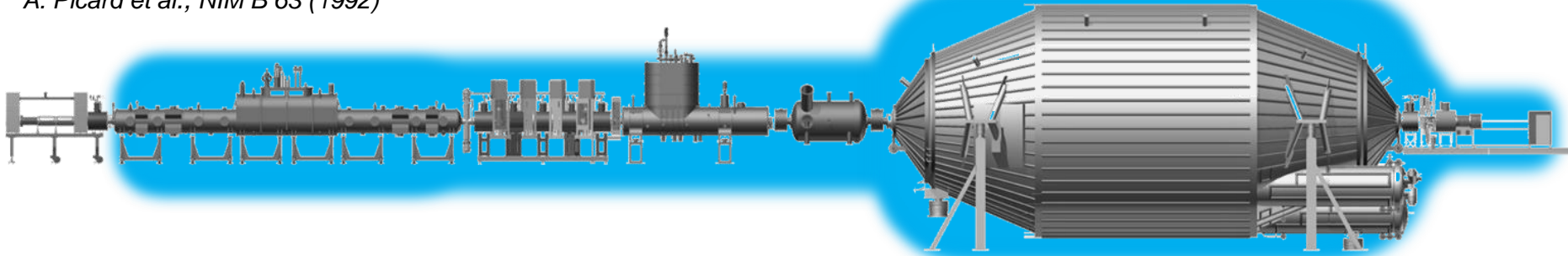

isotropically emitted  
tritium  $\beta$ -electrons

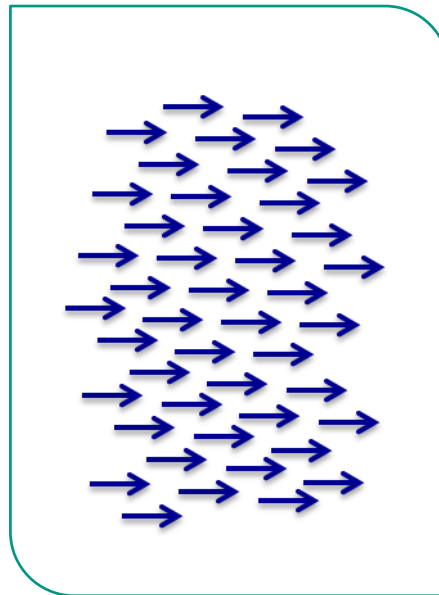

adiabatically collimated  
by magnetic field

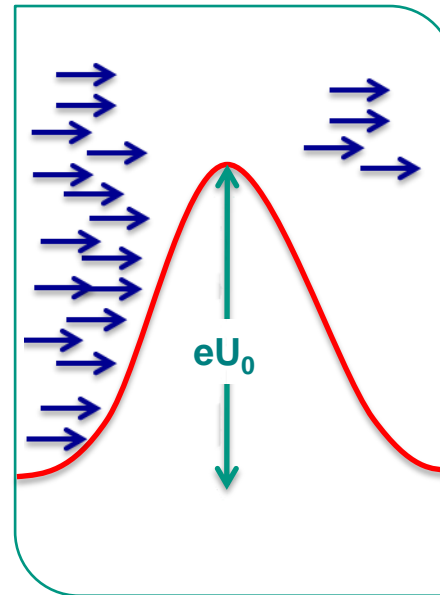

electrons filtered  
by electric potential

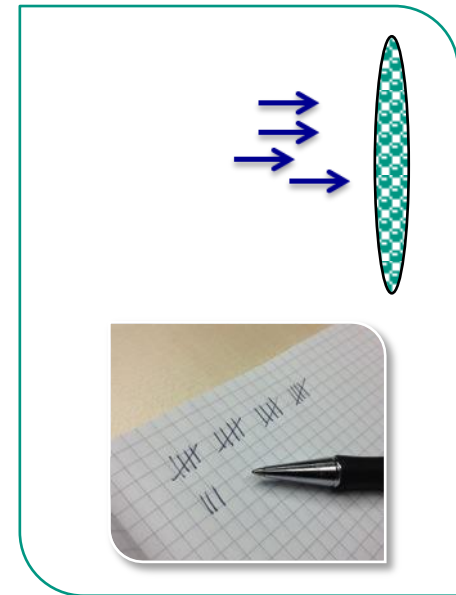

remaining electrons  
counted after filtering

# Magnetic field & electrostatic potential

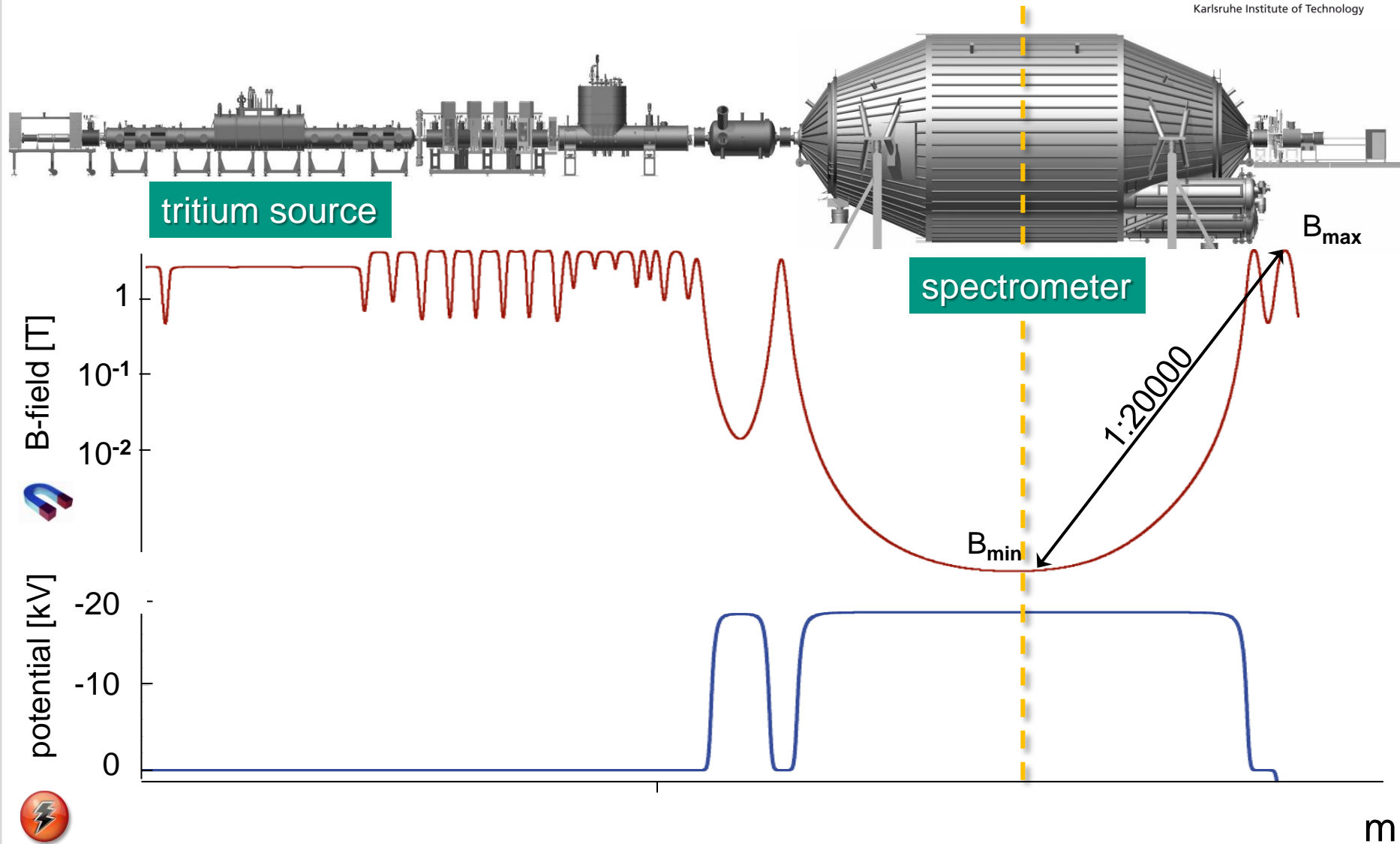

F. Glück, Prog. in Electromagnetics Research B, 32 (2011) 351-388 & 319-350

# KATRIN – benchmark parameters

Windowless Gaseous  
Tritium Source

Cryogenic  
Pumping Section

Main Spectrometer

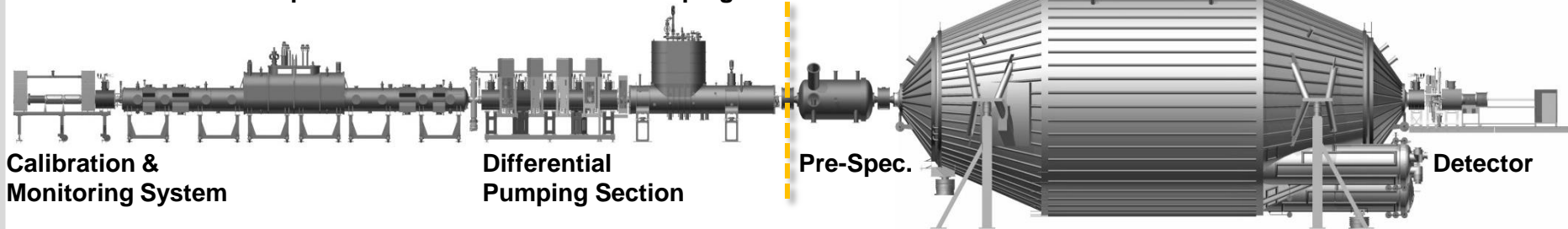

Source & Transport Section (STS)

tritium source:  $10^{11}$   $\beta$ -decays/s

Spectrometer & Detector Section (SDS)

total background:  $10^{-2}$  cps

## experimental challenges

- $10^{-3}$  stability of tritium source column density
- $10^{-3}$  isotope content in source
- $10^{-5}$  non-adiabaticity in electron transport
- $10^{-6}$  monitoring of HV-fluctuations
- $10^{-8}$  remaining ions after source
- $10^{-11}$  mbar in Main Spectrometer
- $10^{-14}$  remaining flux of molecular tritium

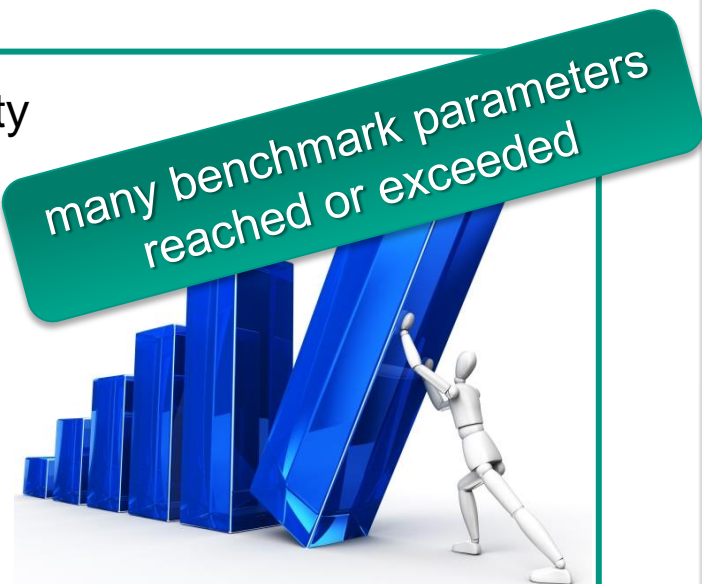

# Source: Tritium Loop and Retention

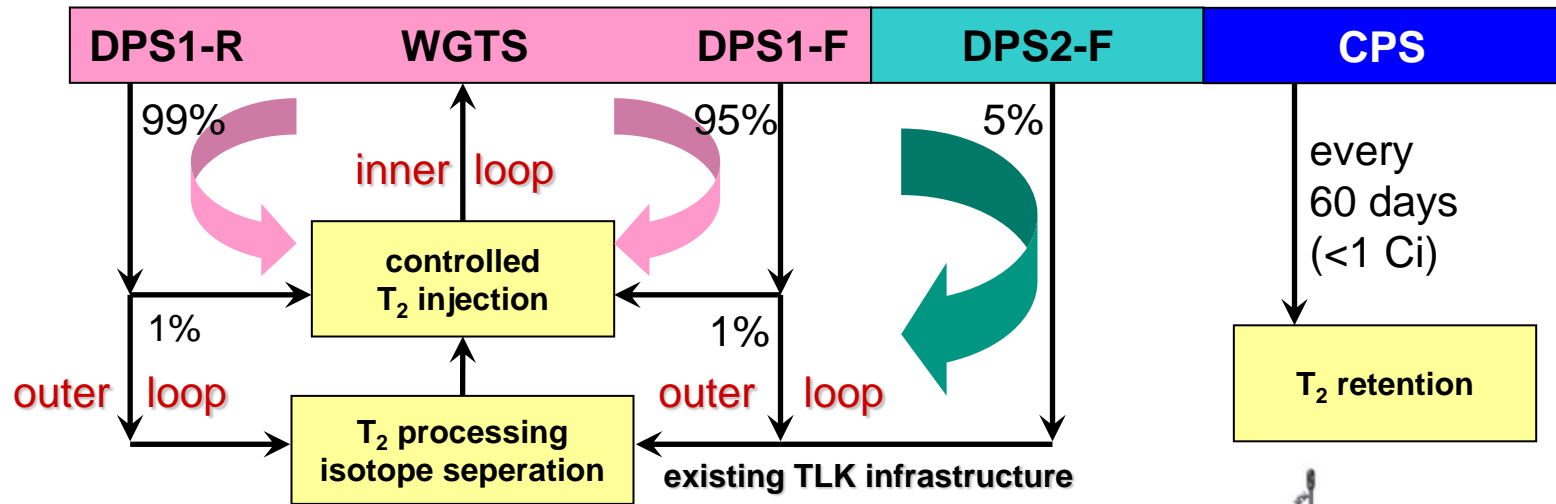

# Windowless Gaseous Tritium Source

## Beam tube temperature

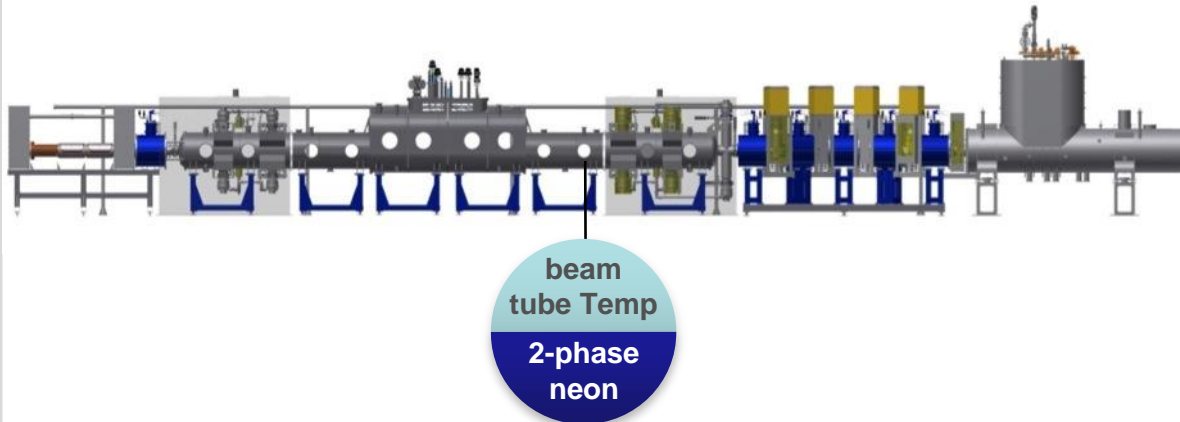

## Challenge

- temperature stability on  $10^{-3}$  level

## Technological development

- novel 2-phase neon cooling system
- required:  $\Delta T = \pm 30$  mK (1 h)
- achieved:  $\Delta T = \pm 1.5$  mK (1 h)

→ **stability surpassing specifications**

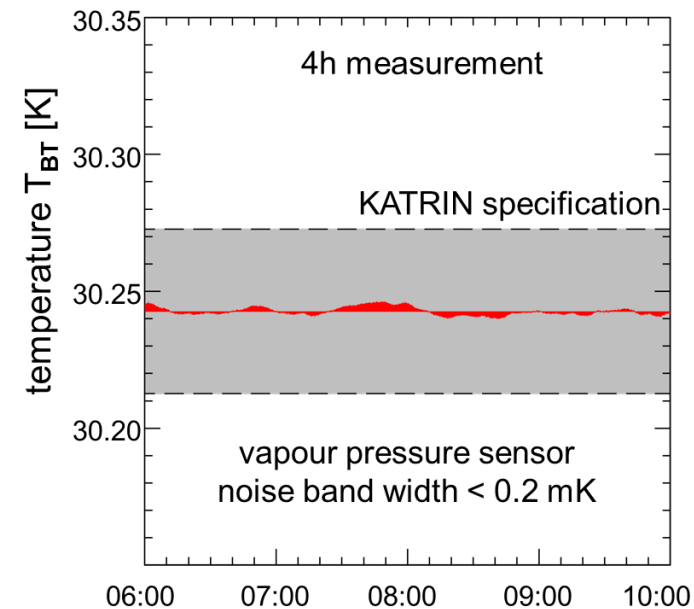



# Windowless Gaseous Tritium Source

## Raman spectroscopy

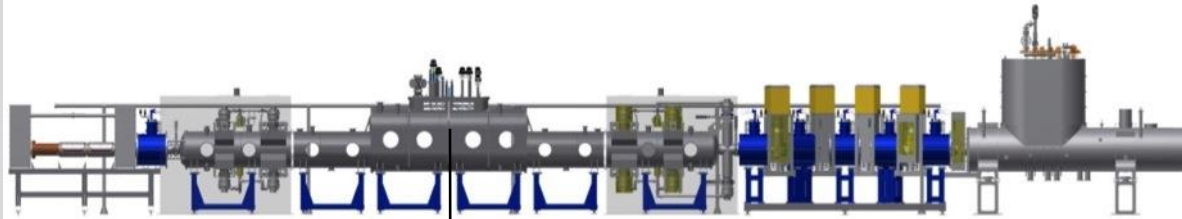

isotopic  
content  
Raman  
spectr.

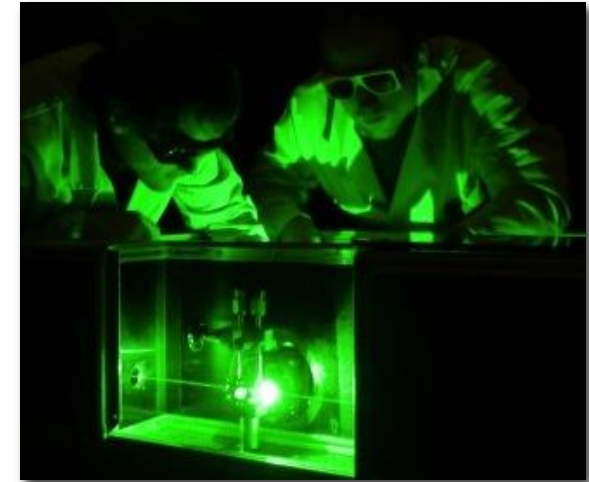

### Challenge

- measure isotopic source content with  $10^{-3}$  accuracy in 100 s

### Technological development

- calibrated Laser-Raman system for all 6 hydrogen isotopologues
- achieved:  $< 10^{-3}$  accuracy in 60 s

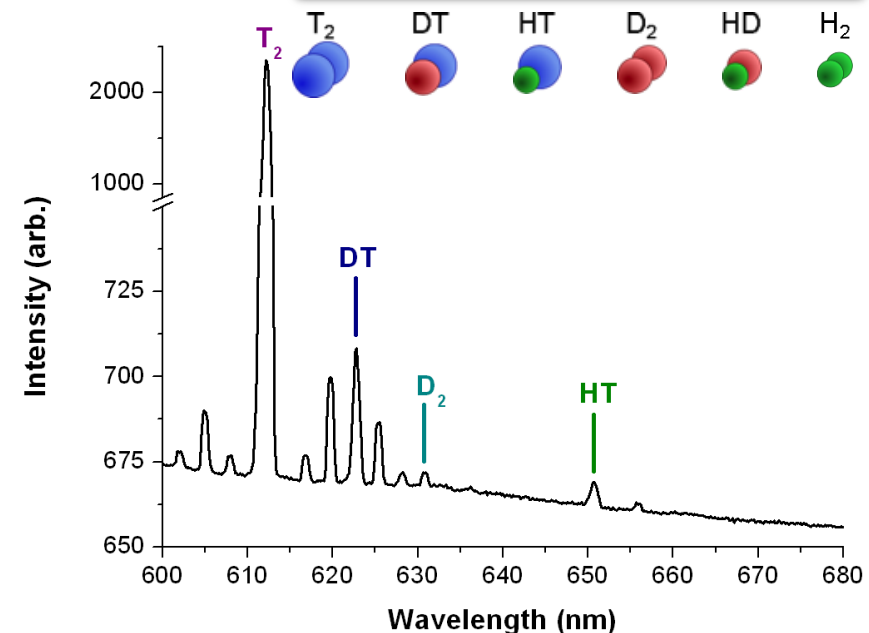

# Tritium Retention Techniques

Suppress tritium flow from source to spectrometer by factor  $> 10^{14}$

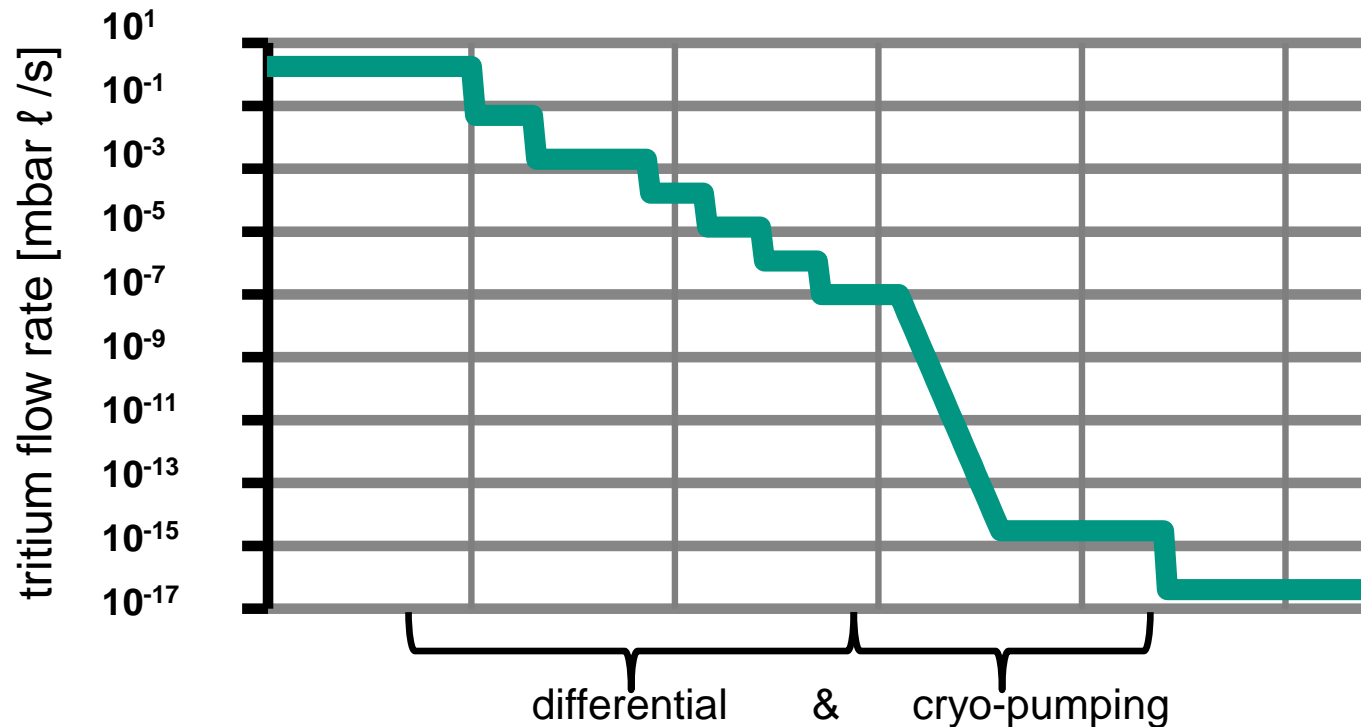
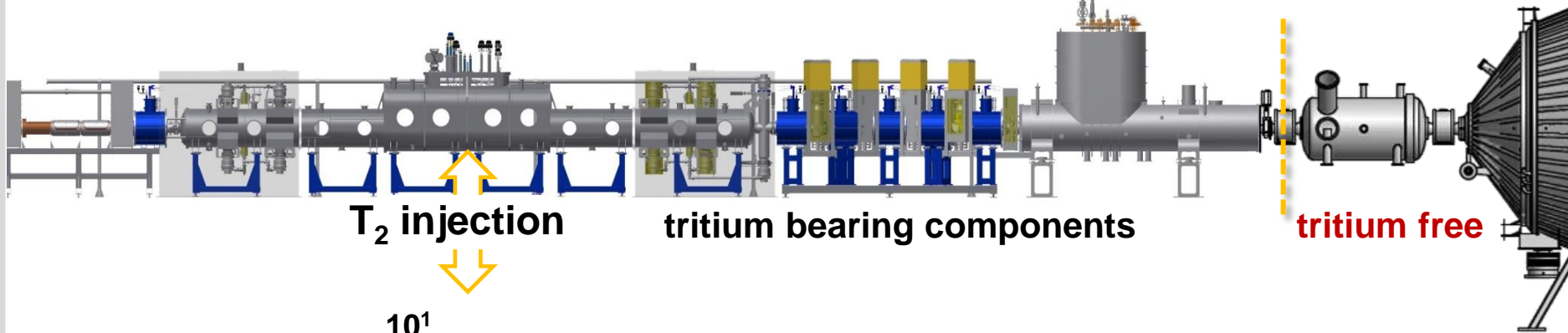

# Transport and Pumping Sections

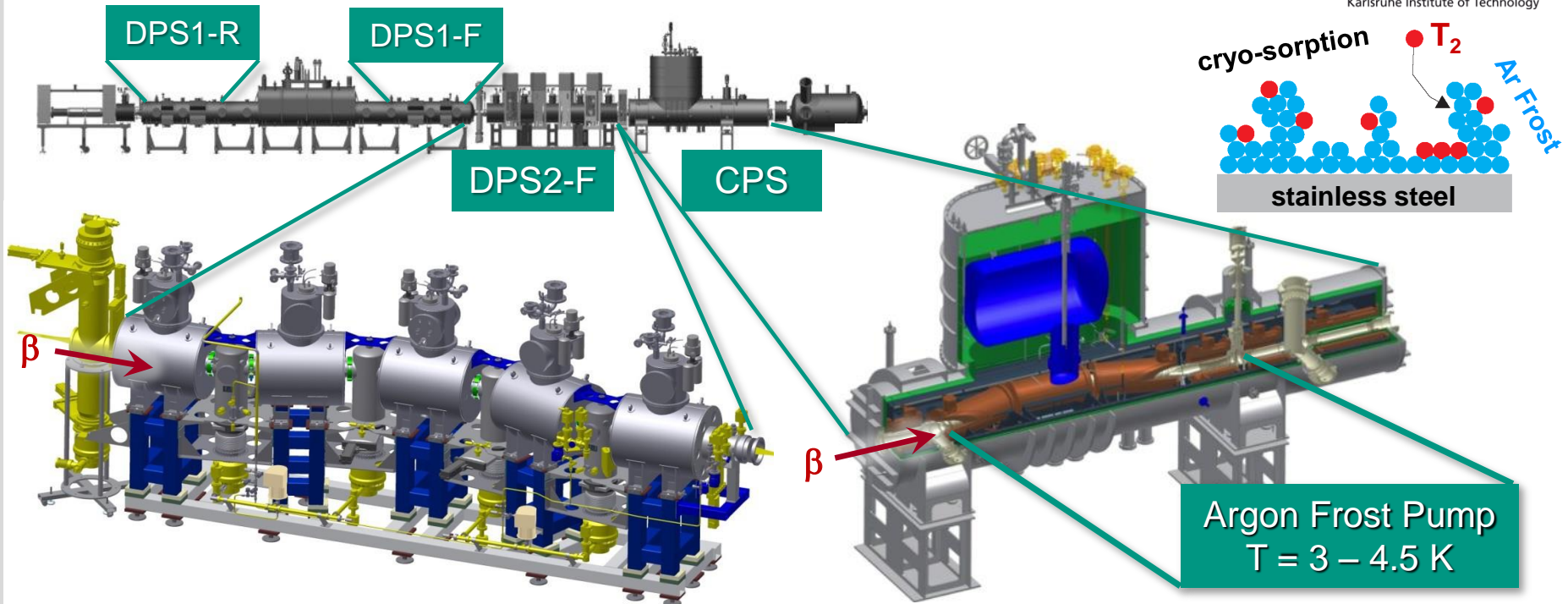

## Differential Pumping Section (DPS)

- active pumping: 6+8+4 TMPs
- Tritium retention:  $10^7$
- magnetic field: 5.6 T
- built at KIT, commissioning 2015

## Cryogenic Pumping Section (CPS)

- based on by cryo-sorption
- Tritium retention:  $>10^7$
- magnetic field: 5.6 T
- delivery, commissioning: 2015

Argon Frost Pump  
T = 3 – 4.5 K

*O. Kazachenko et al., NIM A 587 (2008) 136*

*F. Eichelhardt et al, Fusion Science and Technology 54 (2008) 615*

# Hazaradous operating conditions for TMPs?

## Endurance test for TMP with tritium

- tritium can affect non-metal parts of pump
- TMP type: Leybold MAG-W 2800
- tested at Tritium Laboratory Karlsruhe (TLK)
- one year operation with tritium

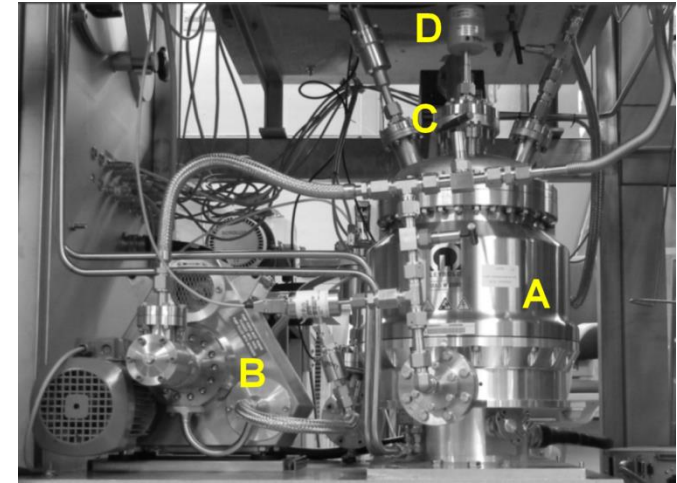

*F. Priester, PhD thesis at KIT (2013), <http://www.katrin.kit.edu/375.php>*

## TMP in a magnetic field

- eddy currents can over-heat rotor
- high mag. field can slow down rotor
- failure of magnetic bearing
- test setup built at KIT for large TMPs
- math. model developed for prediction

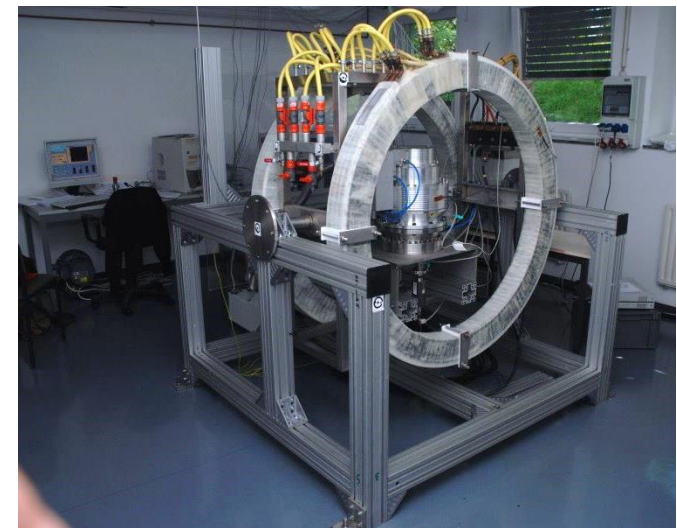

*R. Größle et al., Vacuum 86 (2012) 985-989*

# Results of TMP tritium runs

- total runtime of MAG W2800 at TriToP: **398 days**
- total throughput: **1106 g tritium**
- equivalent to approx. **one year of KATRIN operation**
- RGA spectrum compatible with **H, D, T, N, O** and hydrocarbons
- **no traces of HF, TF** found in Raman spectrum of process gas

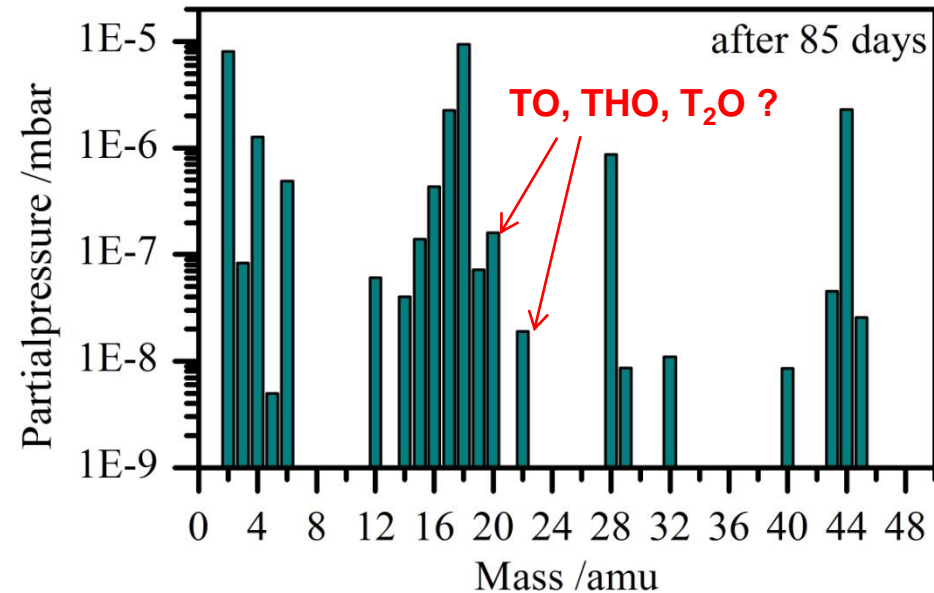
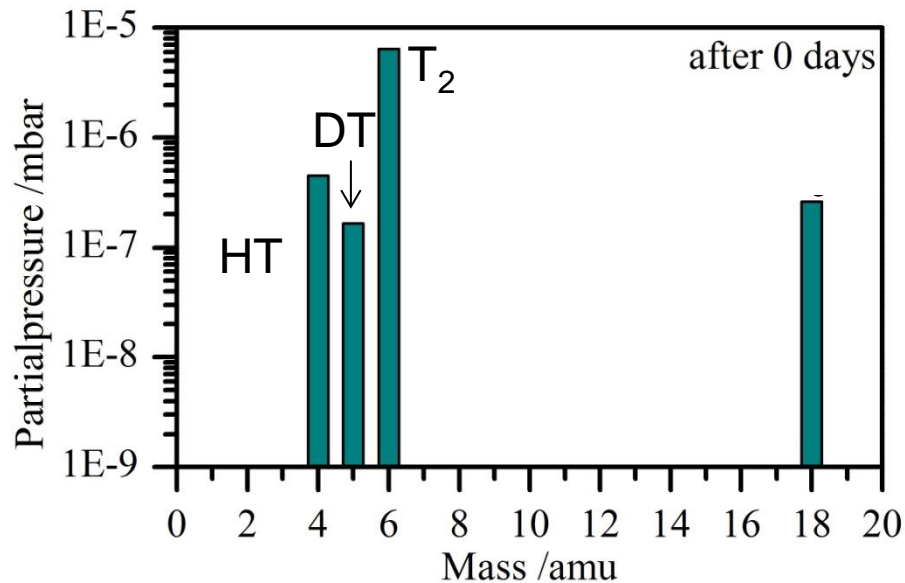

# Complete dismantling of a MAG W 2800

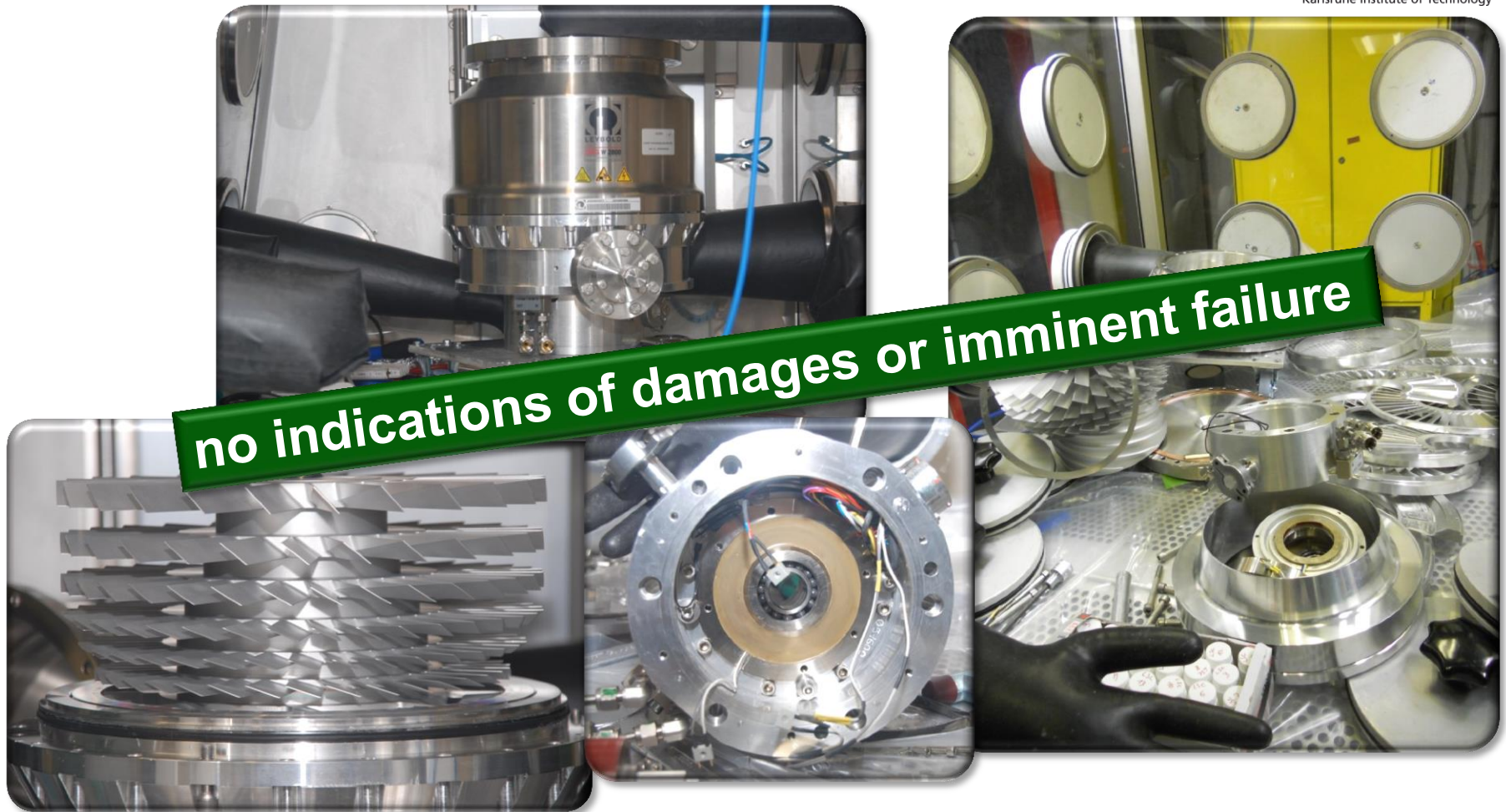

**no indications of damages or imminent failure**

- parts were highly contaminated with tritium, but
- parts looked like new, no indication of wear, cables and O-rings ok

# TMP in a magnetic field

- Helmholtz coils: radius = 60 cm
- B-field: 0 – 50 mT
- coils can be turned by 90°
- pyrometer used for rotor temperature
- gas flow possible

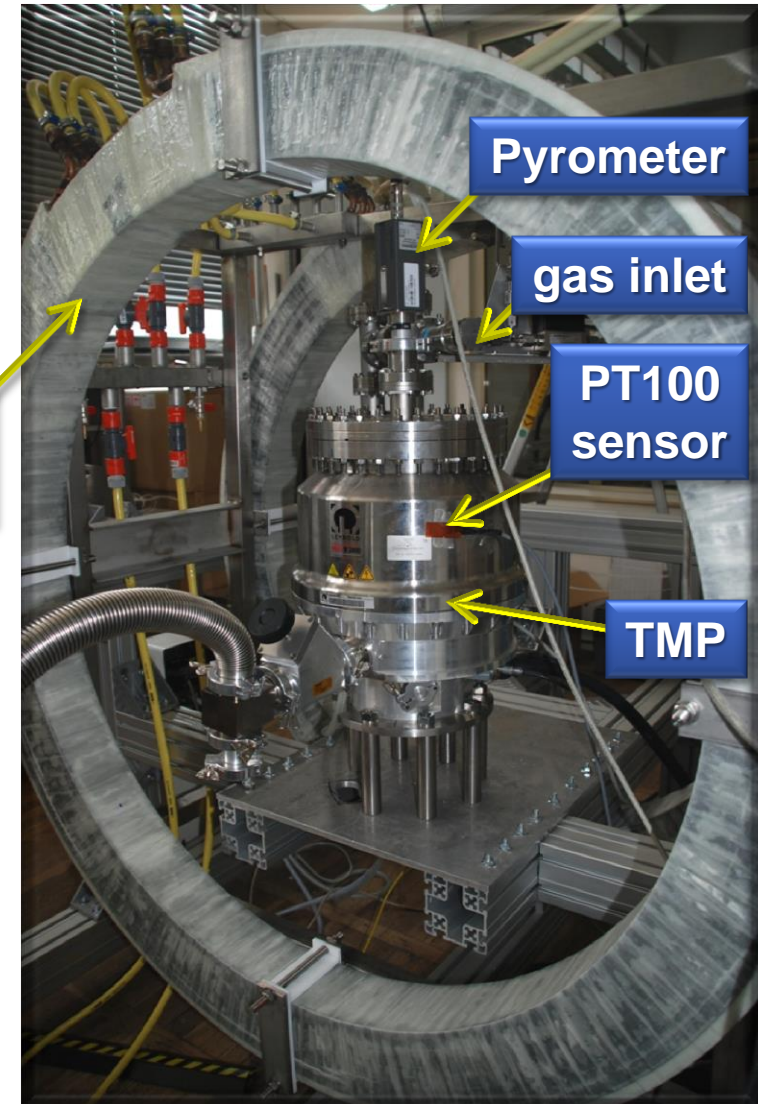
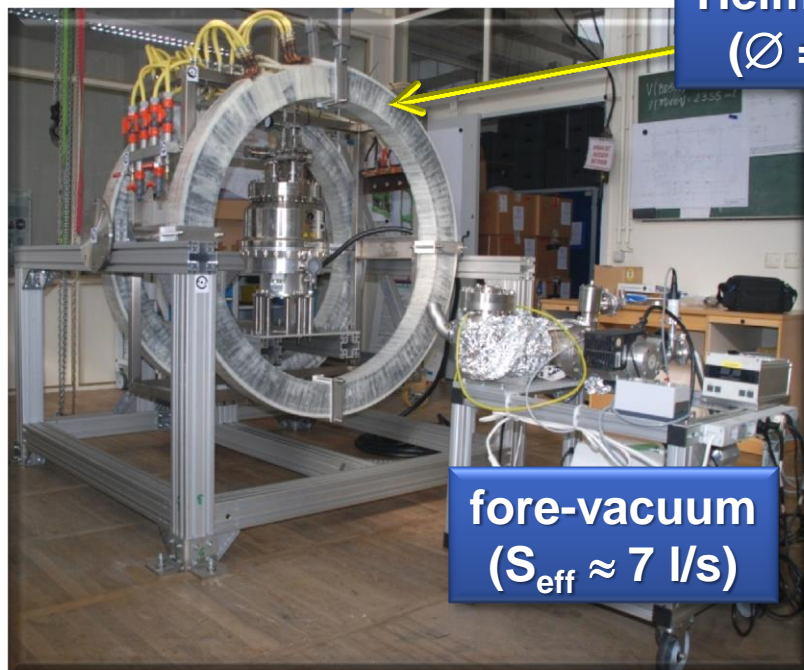

# Model 1: fit of parameters $k_1 \dots k_6$

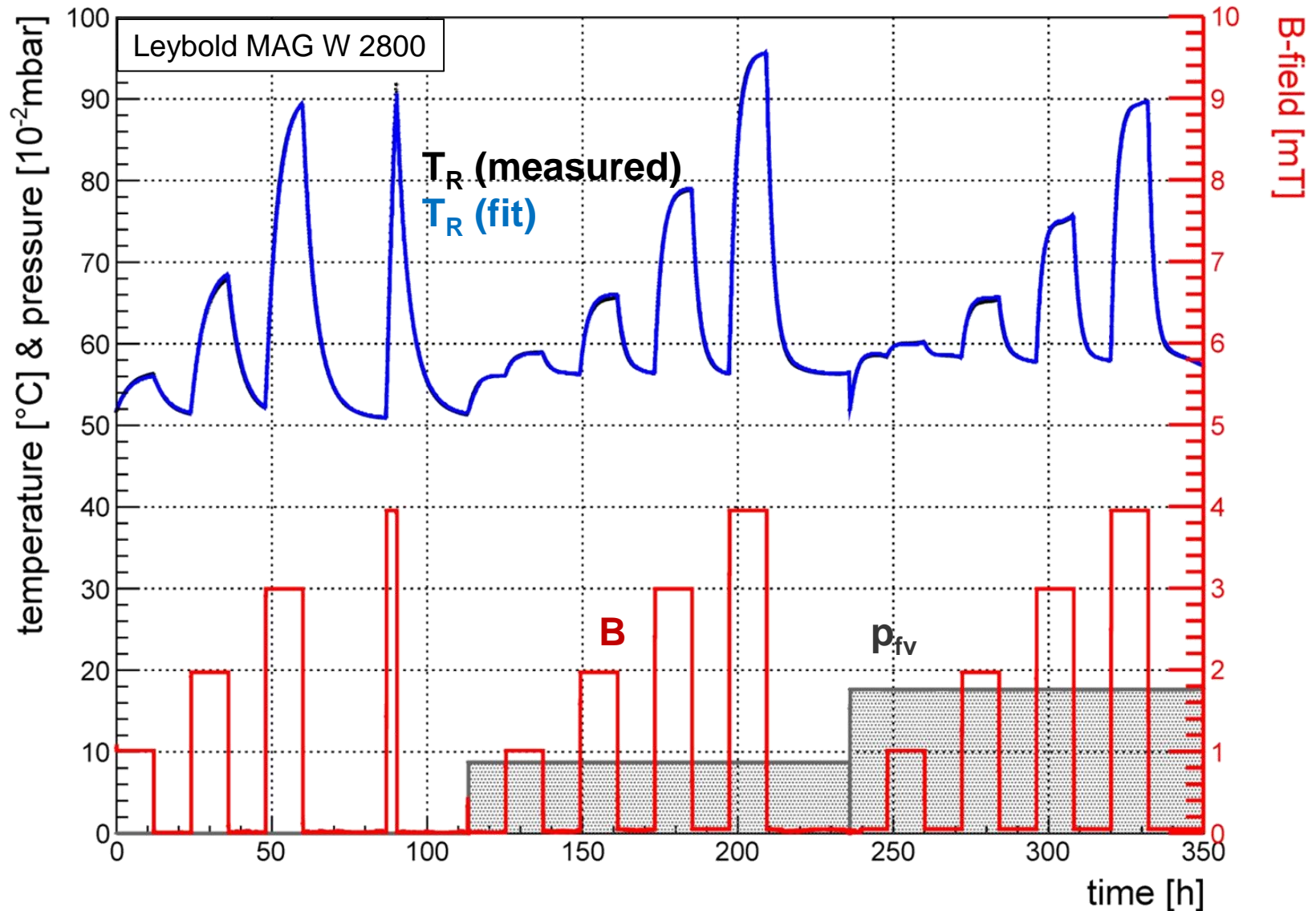



# Model 1: maximum temperature

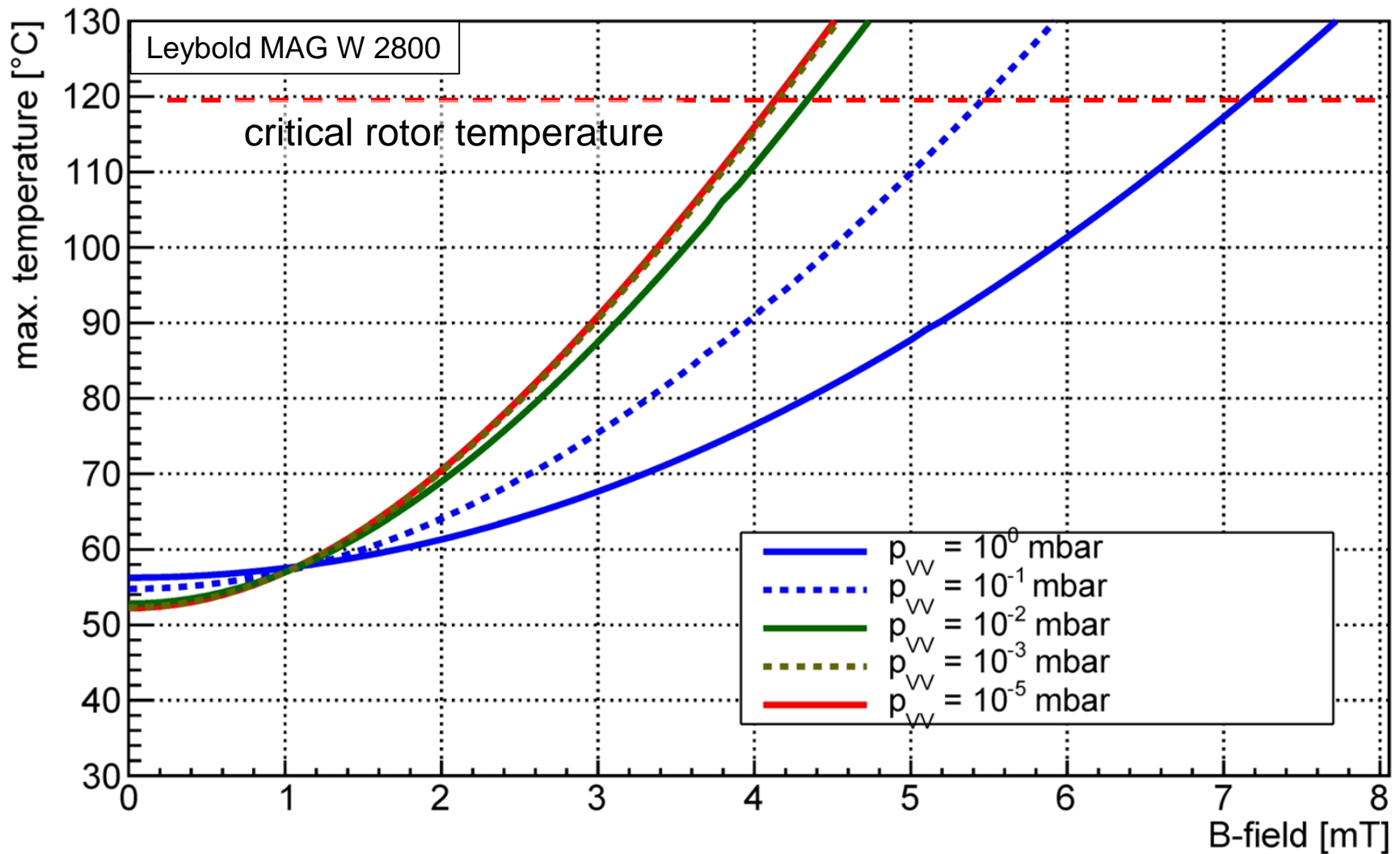

Rotor temperature also depends on cooling temperature !

# Model 1 test:

## Rotor temperature in a pulsed mag. field

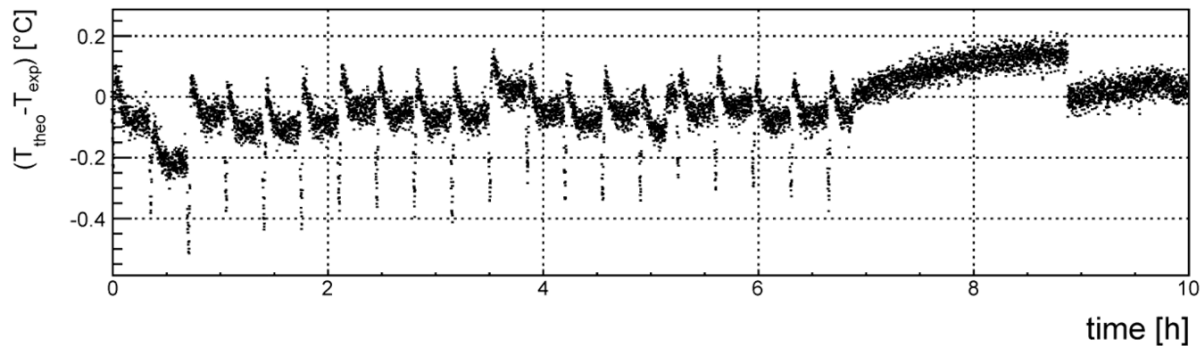
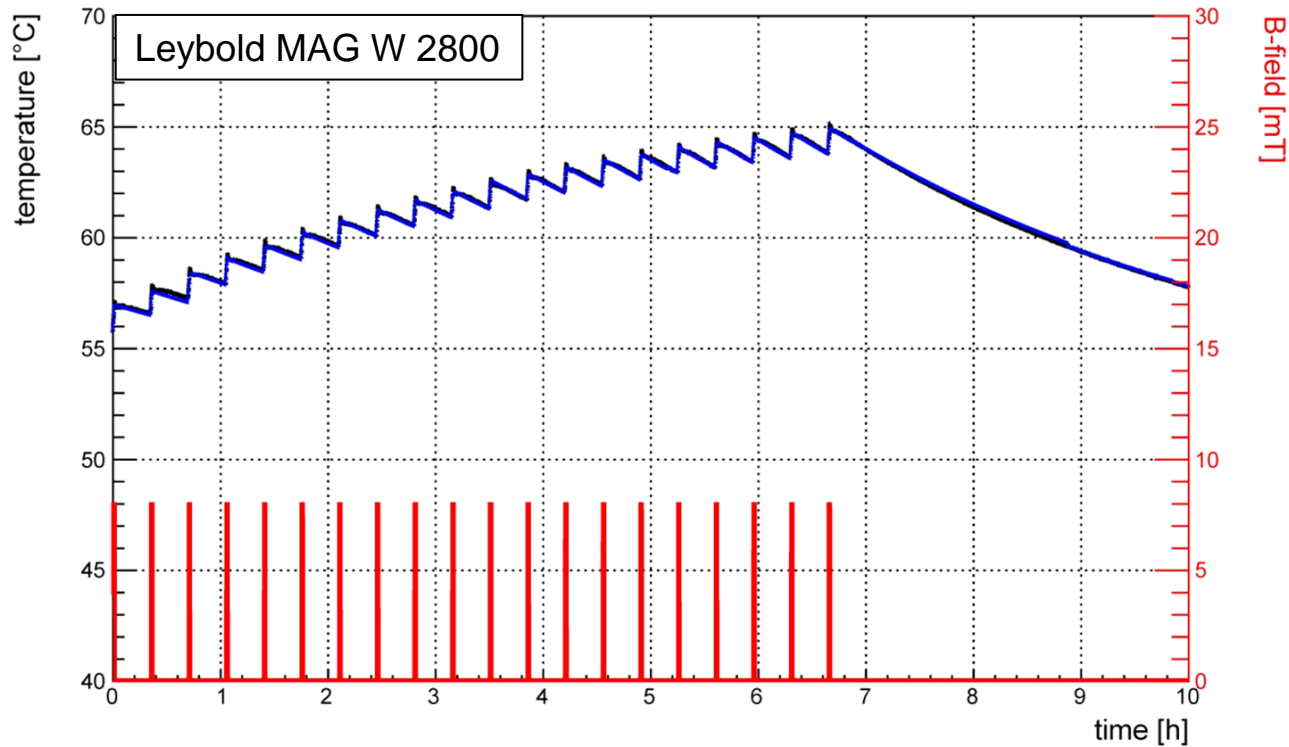

# Influence of magnetic field on TMP

## parallel field:

- failure of magn. bearing (PZ12)
  - for  $B \uparrow$  at 12.6 mT
  - for  $B \downarrow$  at 21.5 mT
- no heating of the rotor

## perpendicular field:

- heating of the rotor (eddy current) < 5 mT
- reduction of rotation speed at 8 - 10 mT
- bearing stable up to 40 mT

## controller in magnetic field:

- fan fails at 6.5 mT
- pump shut down at 11 mT

➤ **TMPs need magnetic shielding at WGTS and DPS**

*(magnetic field values valid for MAG W 2200 and 2800)*

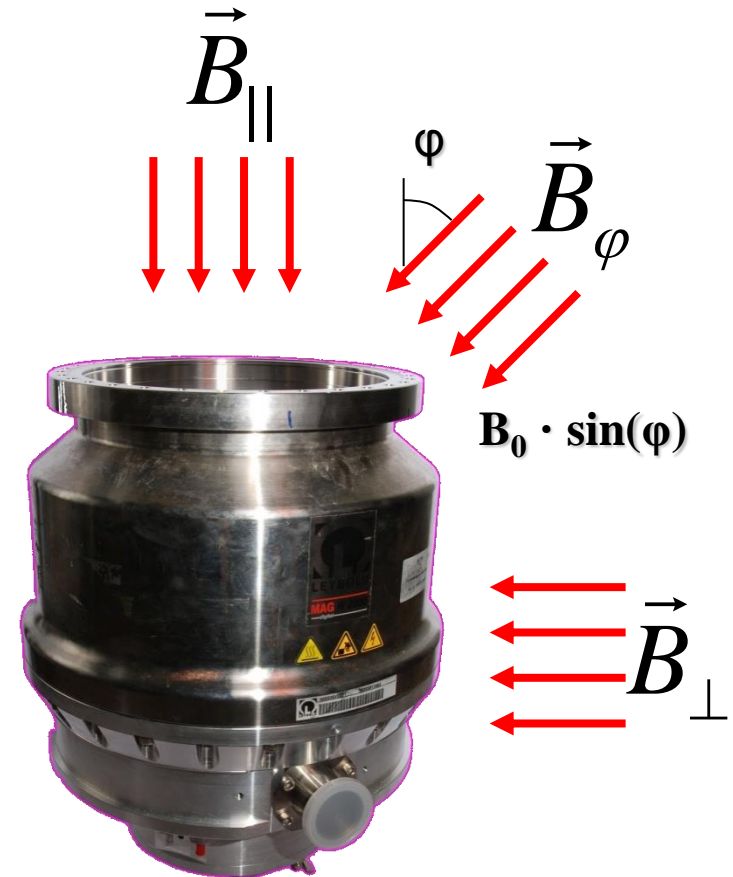

# KATRIN Main Spectrometer

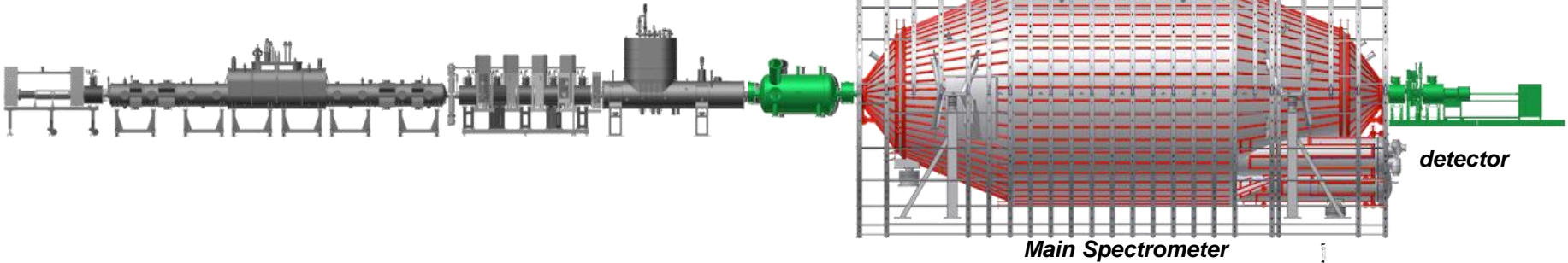

- **MAC-E Filter principle** → precise electron energy measurement

- Vacuum vessel & electrodes on **variable retarding potential (18.6 kV)**
- Magnetic guiding field: **0.3 mT – 6 T**
- High resolution:  **$\Delta E = 0.93 \text{ eV @ } 18.6 \text{ keV}$**

- **Stainless steel (~200 to, 316LN)**

- **Dimensions:**

- diameter: 10 m
- Length: 23 m
- volume: 1240 m<sup>3</sup>
- inner surface: 1240 m<sup>2</sup> (including wire electrodes)

air pressure  
→ 7000 t



# KATRIN Main Spectrometer Vacuum

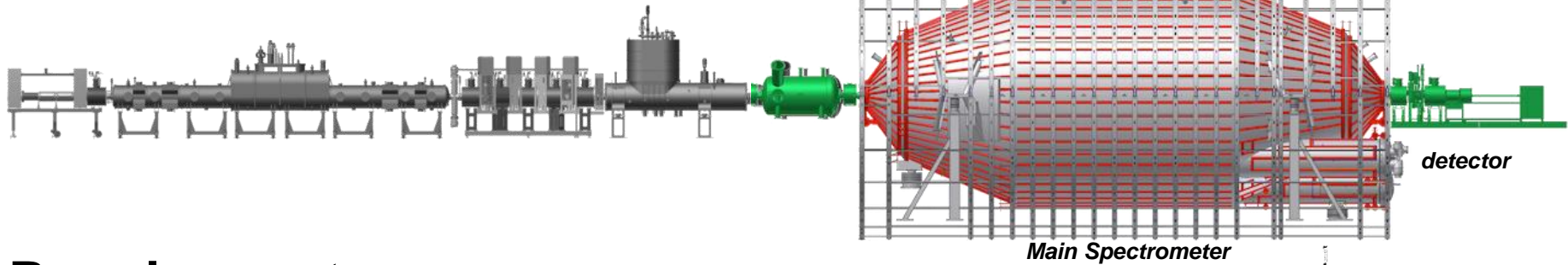

## Requirements:

- **Low pressure ( $< 10^{-11}$  mbar)**
  - tritium partial pressure  $< 10^{-21}$  mbar
  - few radon decays per day
  - outgassing rate  $< 10^{-12}$  mbar·ℓ/s·cm<sup>2</sup>
  - total leak rate  $< 5 \cdot 10^{-9}$  mbar·ℓ/s
- **Bakable at 350°C (NEG activation)**
- **Stable operation at 20°C**
- **Vacuum components operated in**
  - Magnetic field: 0.3 mT – 6 T
  - Electric potential: 18.6 kV



# KATRIN Main Spectrometer (Deggendorf)



# KATRIN Main Spectrometer Journey to KIT

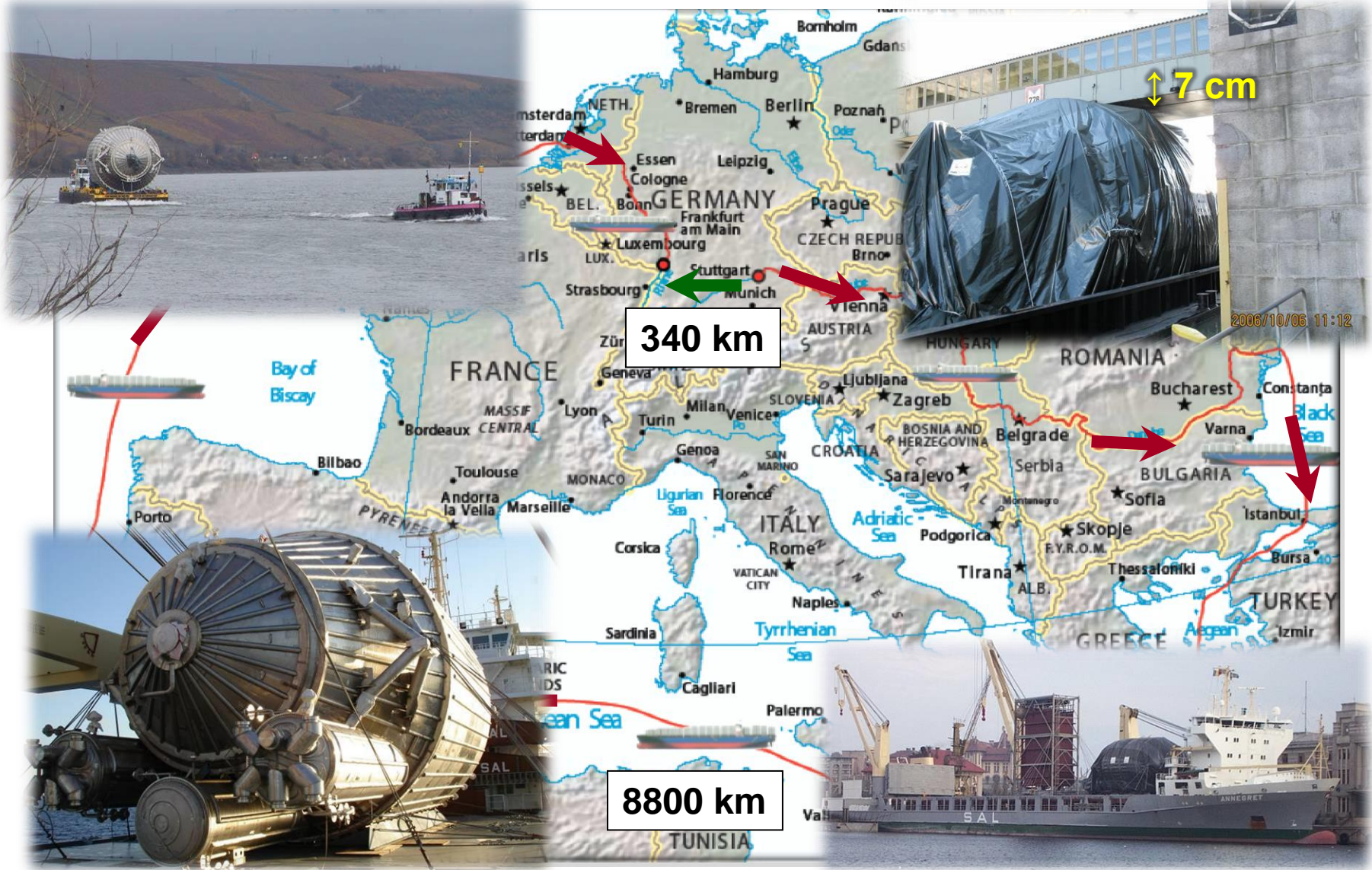

26.11.2006





# KATRIN Main Spectrometer Vacuum

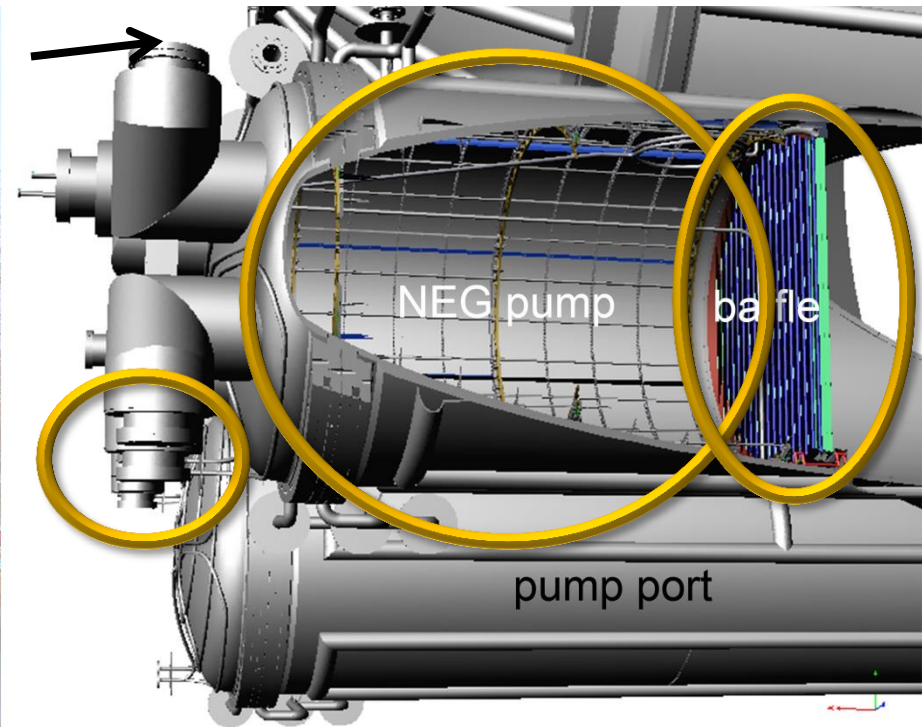
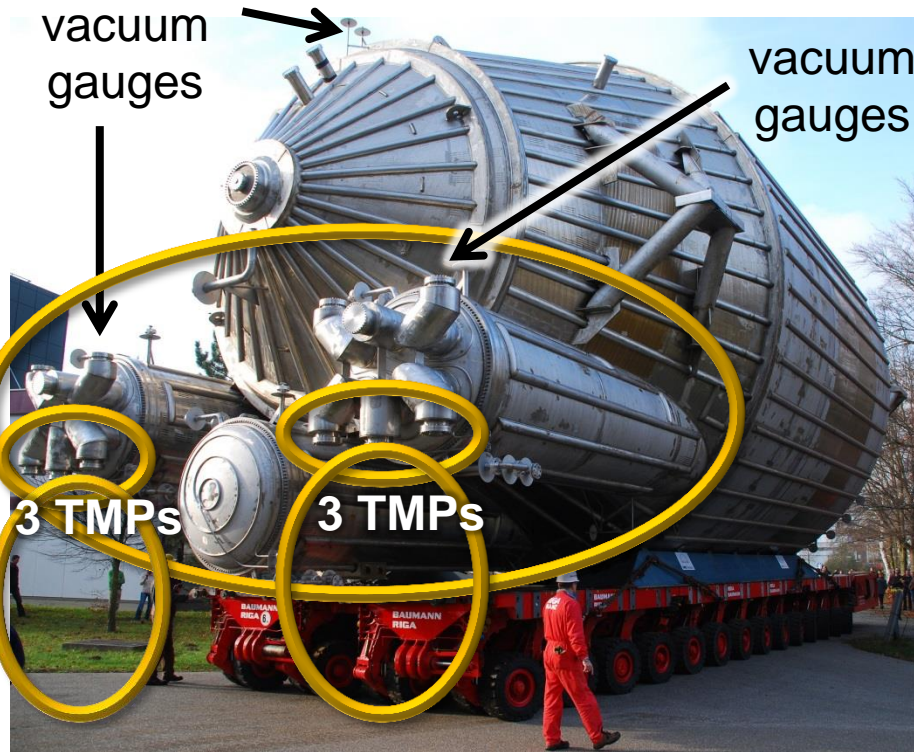

- Roughing pump: 640 m<sup>3</sup>/h screw-pump
- 6 turbo-molecular pumps (Leybold MAG-W 2800): 10 000 ℓ/s (H<sub>2</sub>)
- Fore-vacuum: 300 ℓ/s TMP and scroll pump (30 m<sup>3</sup>/h)
- 3 NEG-pumps (3000 m SAES St707 getter strips): ~~~10<sup>6</sup> ℓ/s (H<sub>2</sub>)~~ 400 000 ℓ/s
- 3 cryogenic LN<sub>2</sub> baffles (radon): ~170 000 ℓ/s (Rn)

## Flanges and Gaskets:

### ■ UHV:

- CF flanges up to 250 mm
- HTMS double gaskets:
  - 500 mm flanges at ground-electrodes
  - 1700 mm flanges at pump ports
- all gaskets bakable at 350°C

### ■ intermediate vacuum:

- CF flanges

### ■ fore-vacuum:

- KF flanges (Viton O-rings)
- ISO K for pump-down and venting

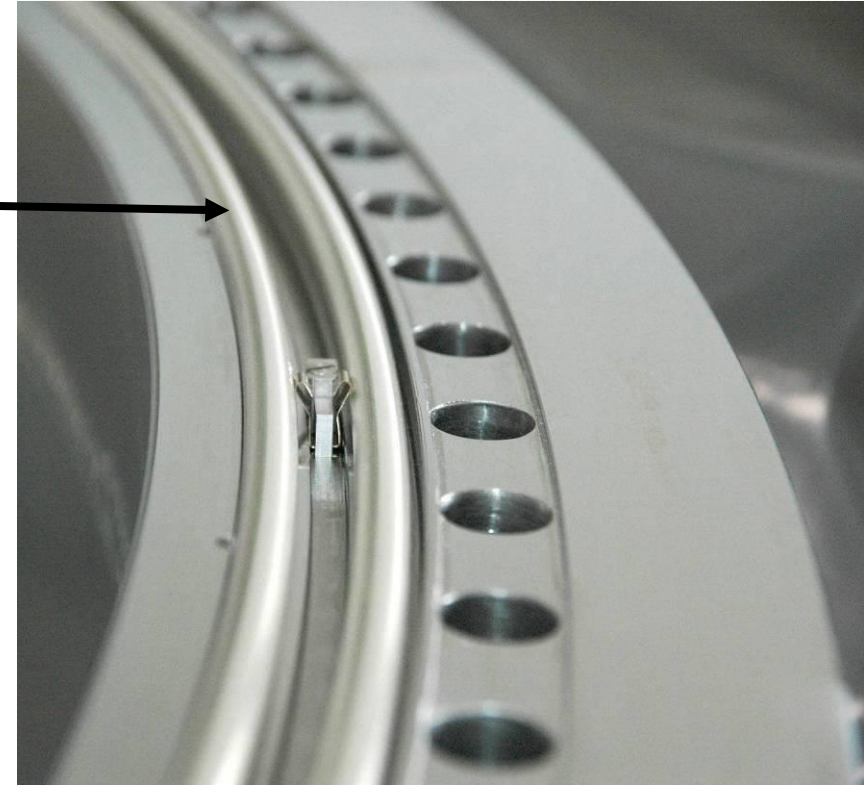

# Radon as background source (problem)

- $^{219}\text{Rn}$  emanation from St707 NEG getter strips (3000 m) in pump ports
- $^{220}\text{Rn}$  emanation from stainless steel walls/weldings
- electrons trapped in B field for hours
- they produce secondary electrons by ionization

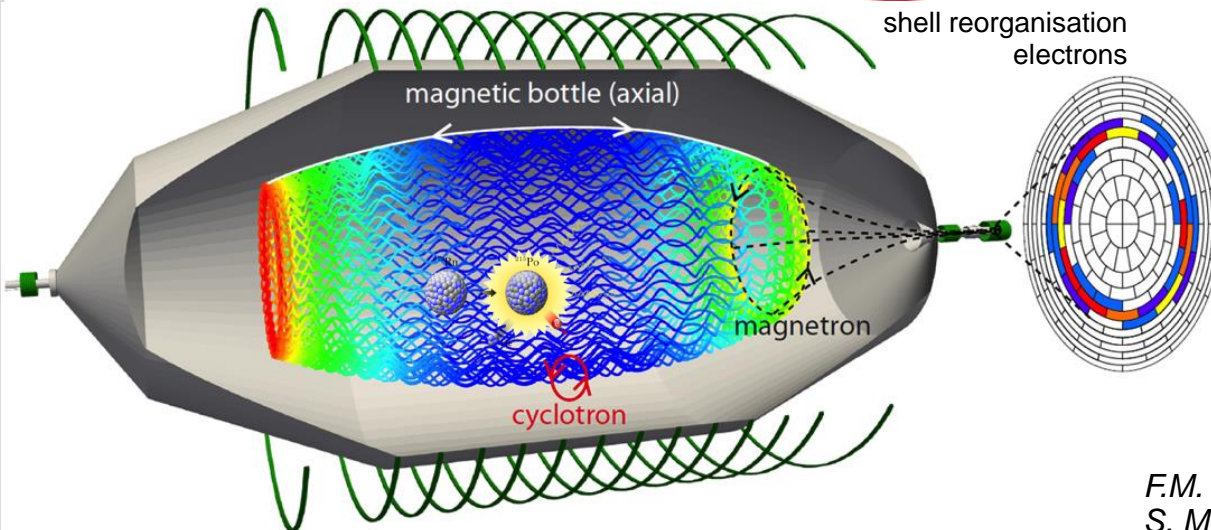
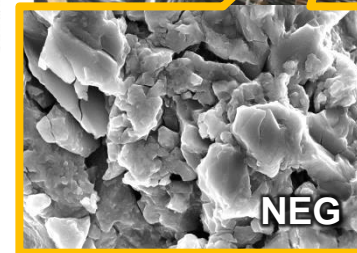
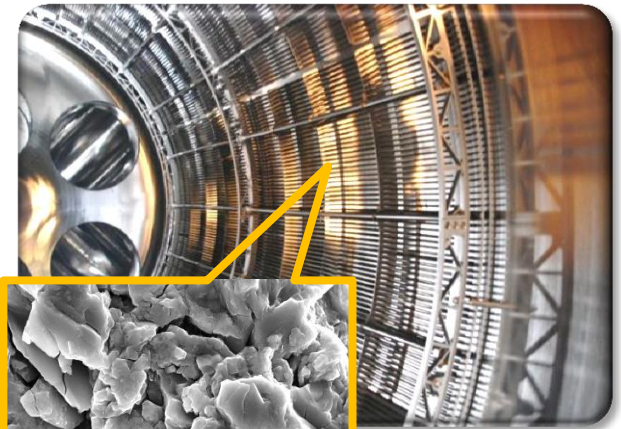
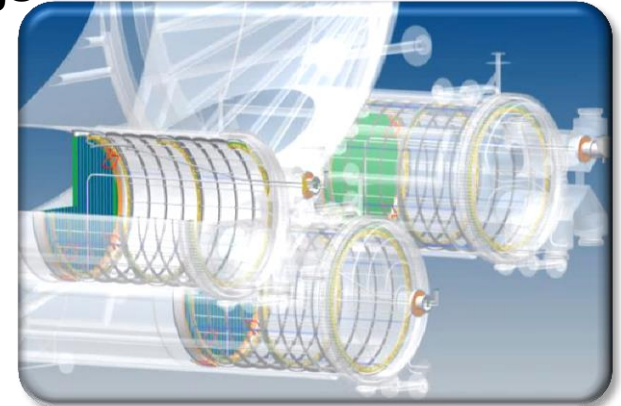

F.M. Fränkle et al., *Astropart. Phys.* 35 (2011) 128  
 S. Mertens et al., *Astropart. Phys.* 41 (2013) 52

# Radon as background source (solution)

- passive background reduction: LN<sub>2</sub>-cooled baffles to cryo-sorb <sup>219</sup>Rn

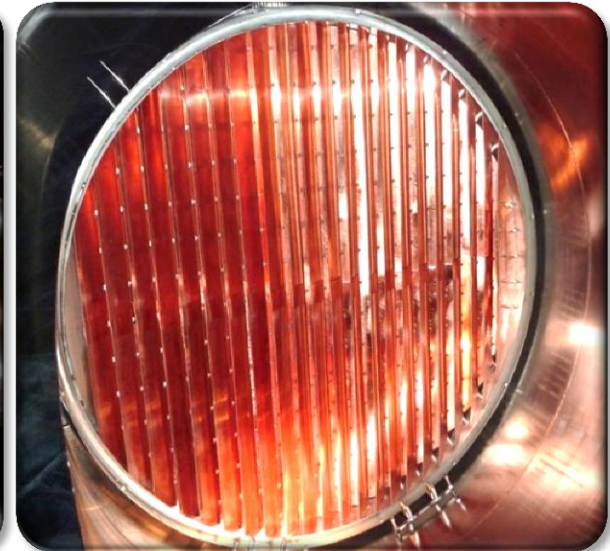
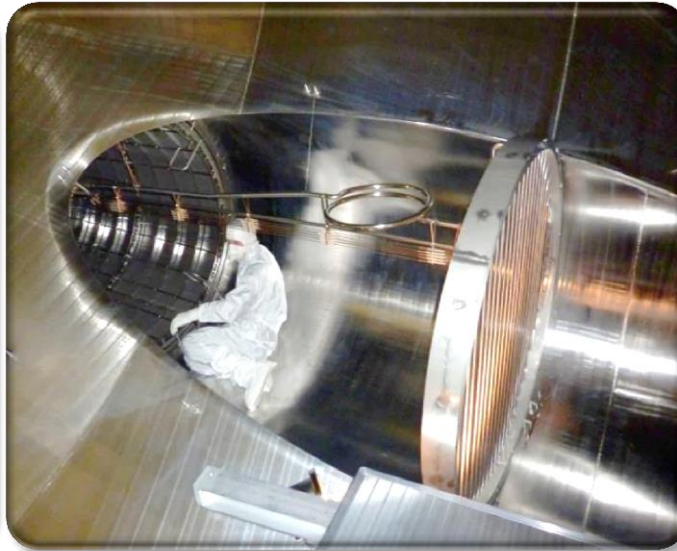
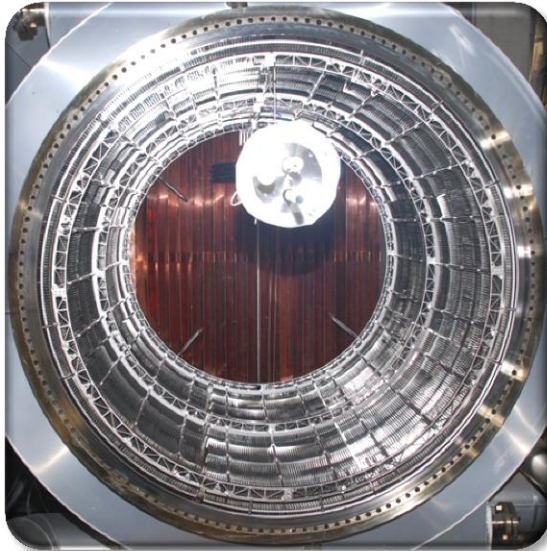

- reduction of effective NEG pumping speed: 40%
- reduction of Rn flow into main volume : ~ 0.4%
- pumping speed for Rn from walls: 170 000 ℓ/s

# KATRIN Main Spectrometer and Detector Commissioning 2013

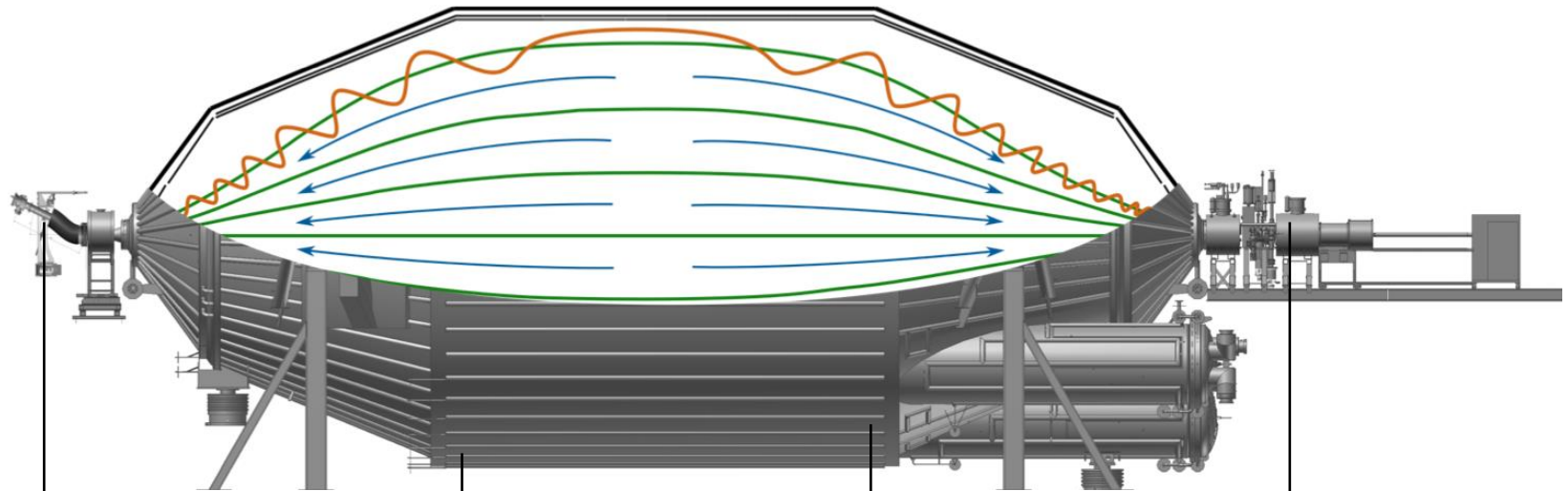

angular  
selective  
electron gun  
transmission  
function  
properties

MAC-E filter,  
energy analysis  
vessel on HV,  
wire electrode

UHV  
conditions  
 $10^{-11}$  mbar  
6 weeks baking,  
 $T_{\max} = 300$  °C

Si-PIN  
detector  
low background,  
148 pixel

# 2008 – 2012: Wire Electrode Installation

- **248 wire electrodes on the inner surface**
  - 23 440 insulated wires
  - 120 000 individual parts
- **Installed under cleanroom conditions**

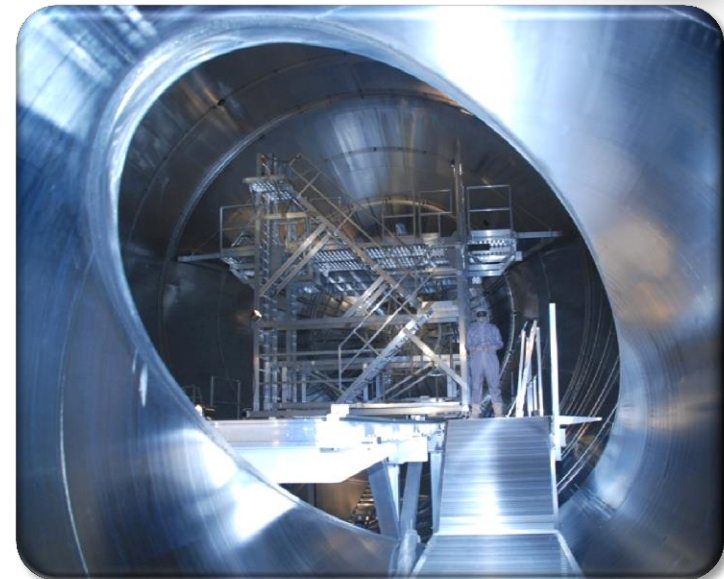

# 2012: All Components Installed

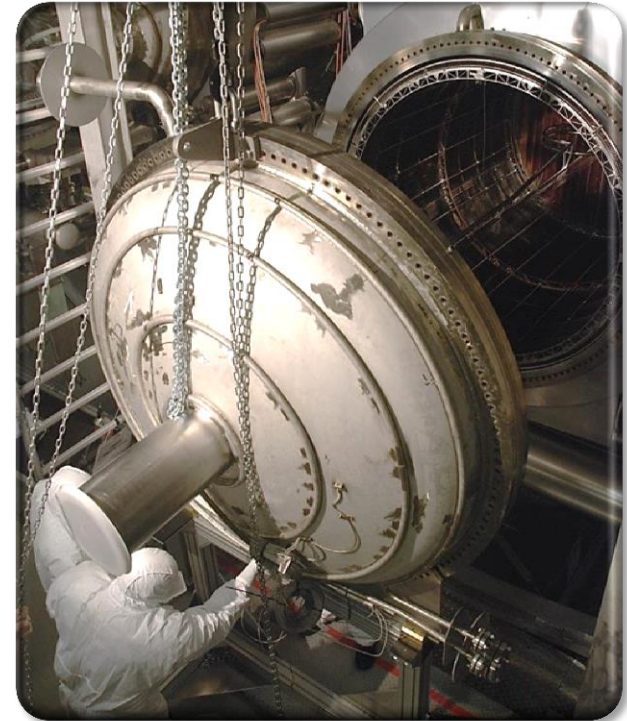
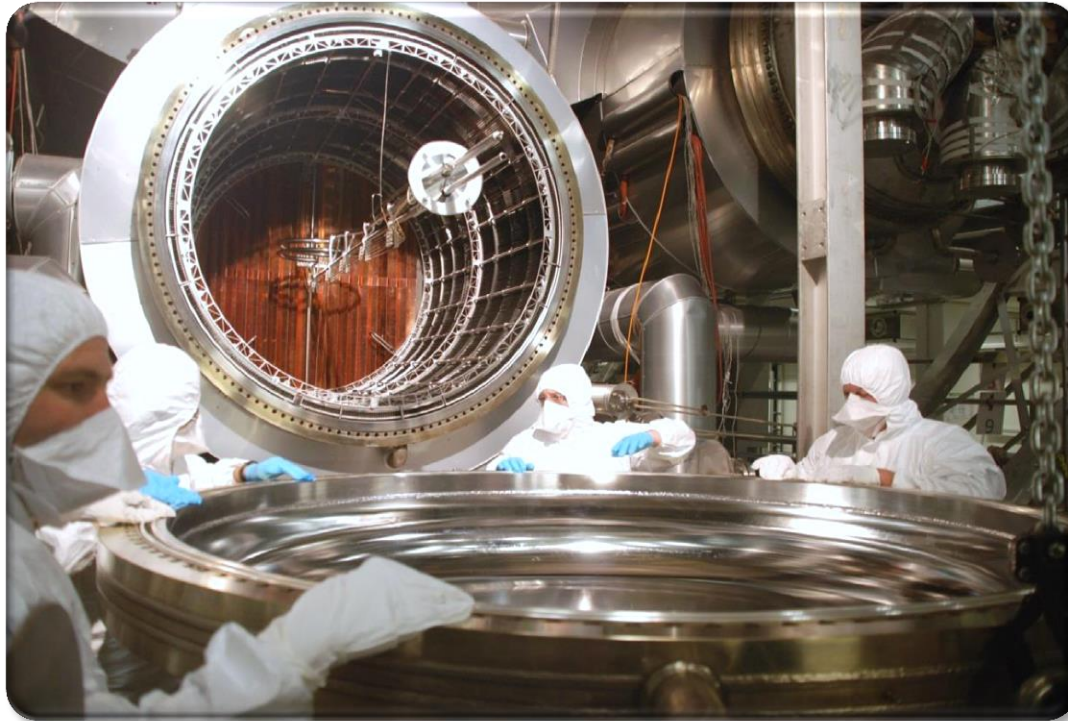

- **Electrode installation completed**
- **Vacuum system installed**
- **Successful leak test**
- **Commissioning of heating and vacuum control system (PCS7)**

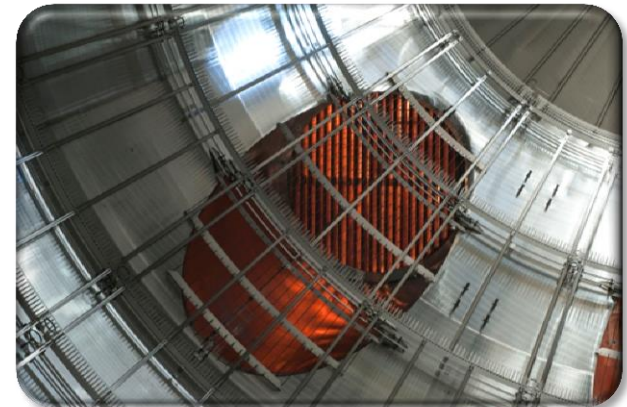

# Spectrometer Commissioning: Bake-out

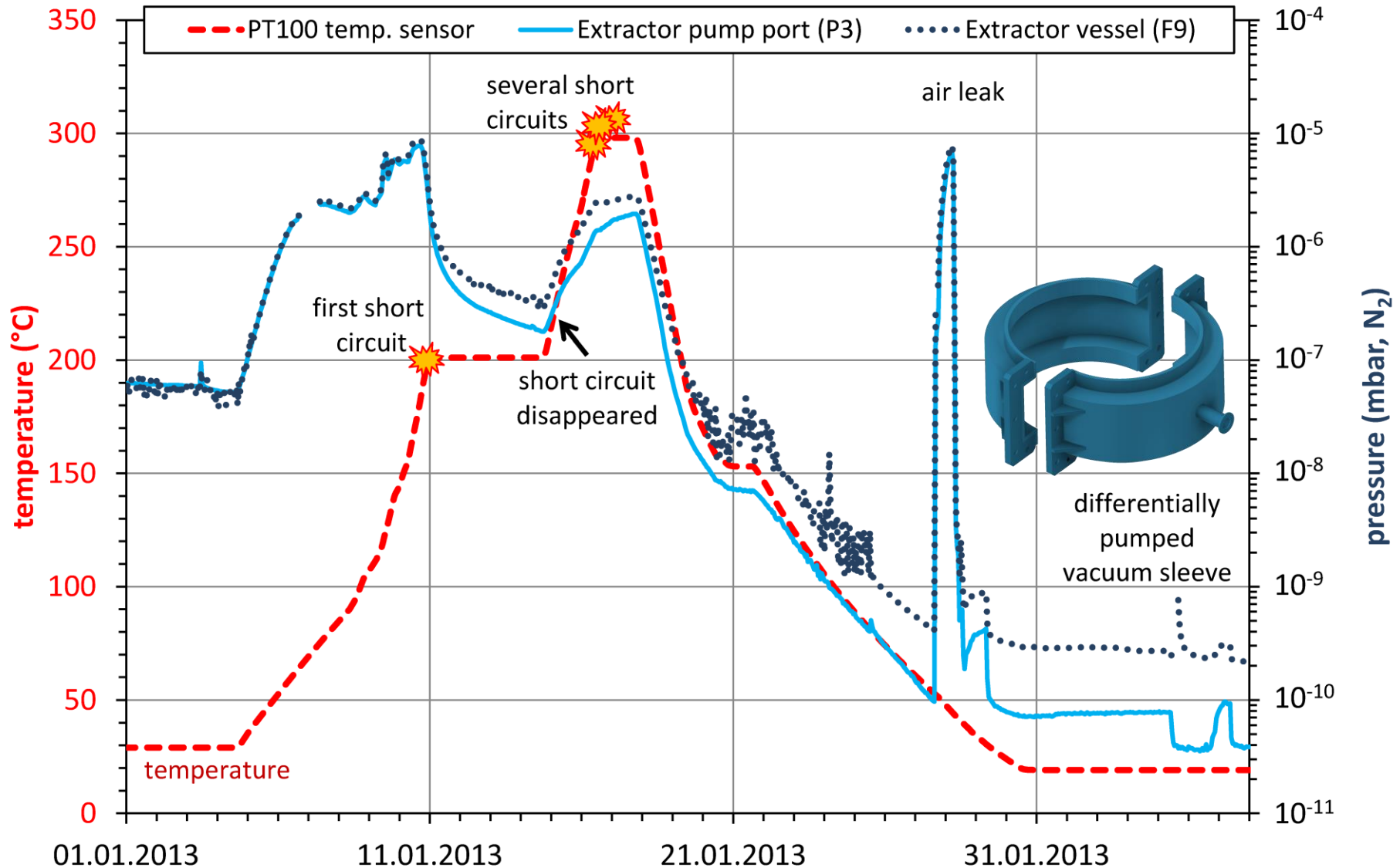



# Baking of the Main Spectrometer

- Duration of baking: 4 weeks
- 24/7 shifts
- Max. temperature: 300°C
- Heating rate: 1°C – 5°C/h
- Thermal expansion during bake-out: ~ 10 cm

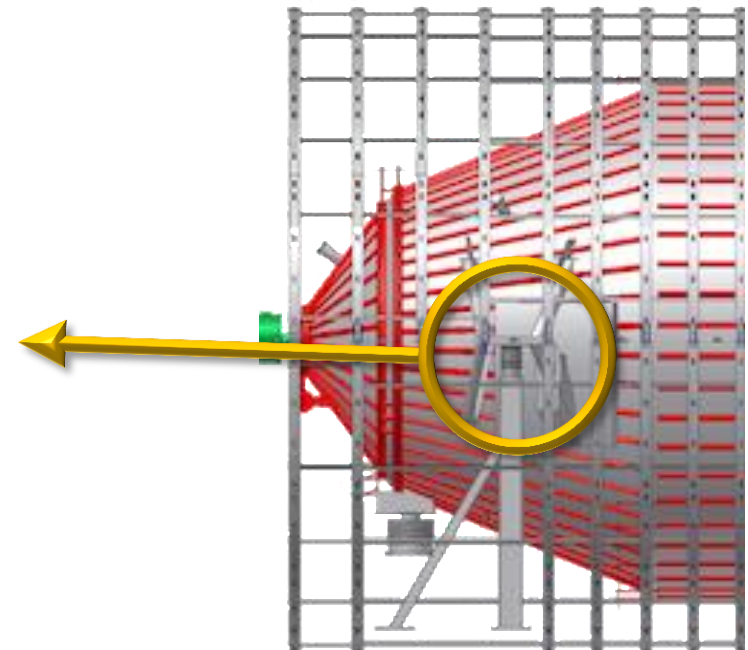
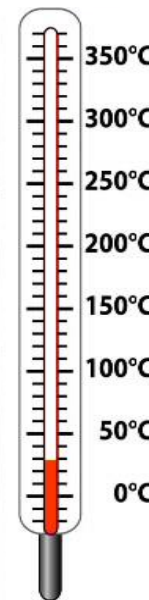

# Vacuum status after bake-out

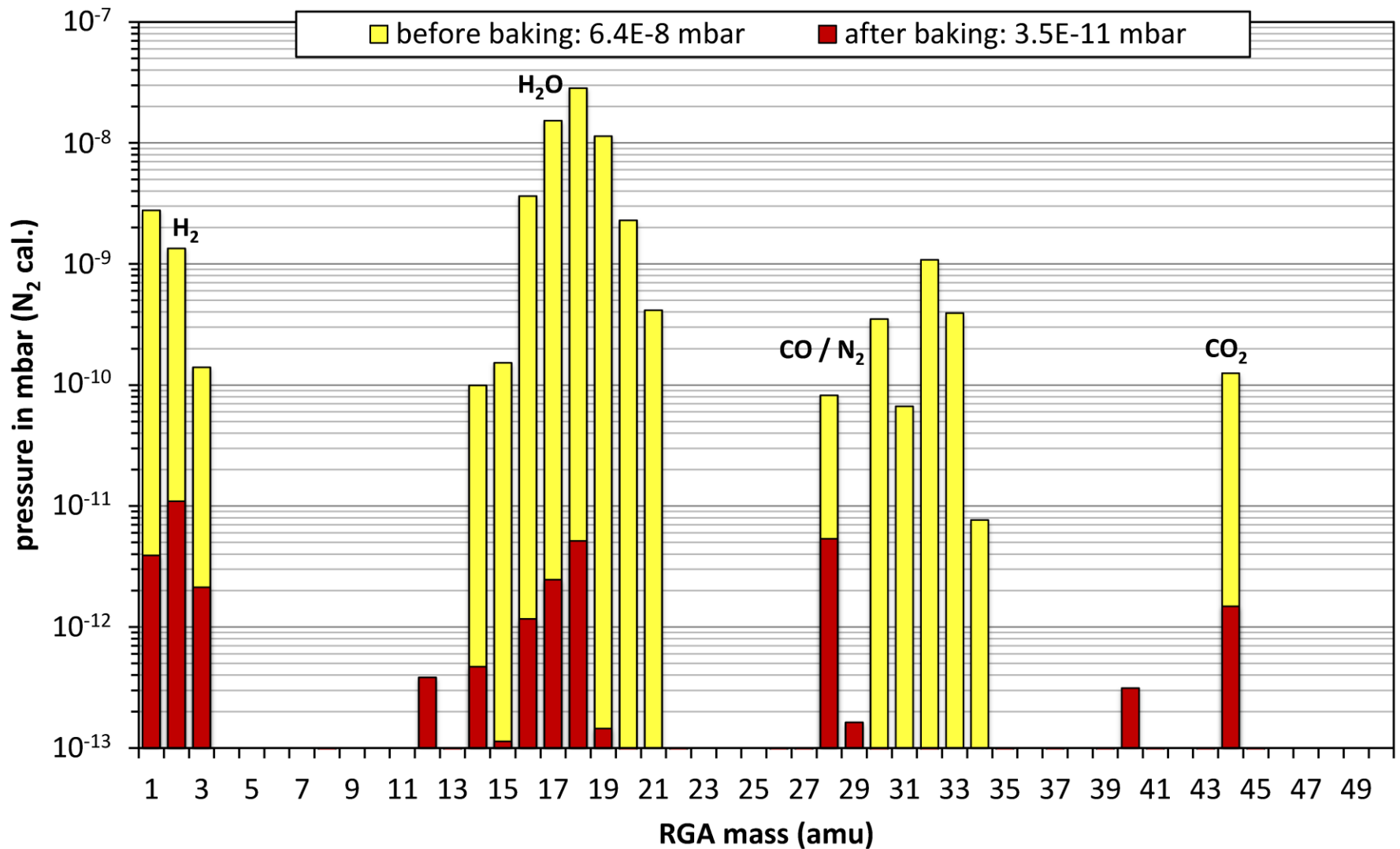

# NEG activation

## Indicator for NEG activation:

- pressure ratio between vessel and pump port

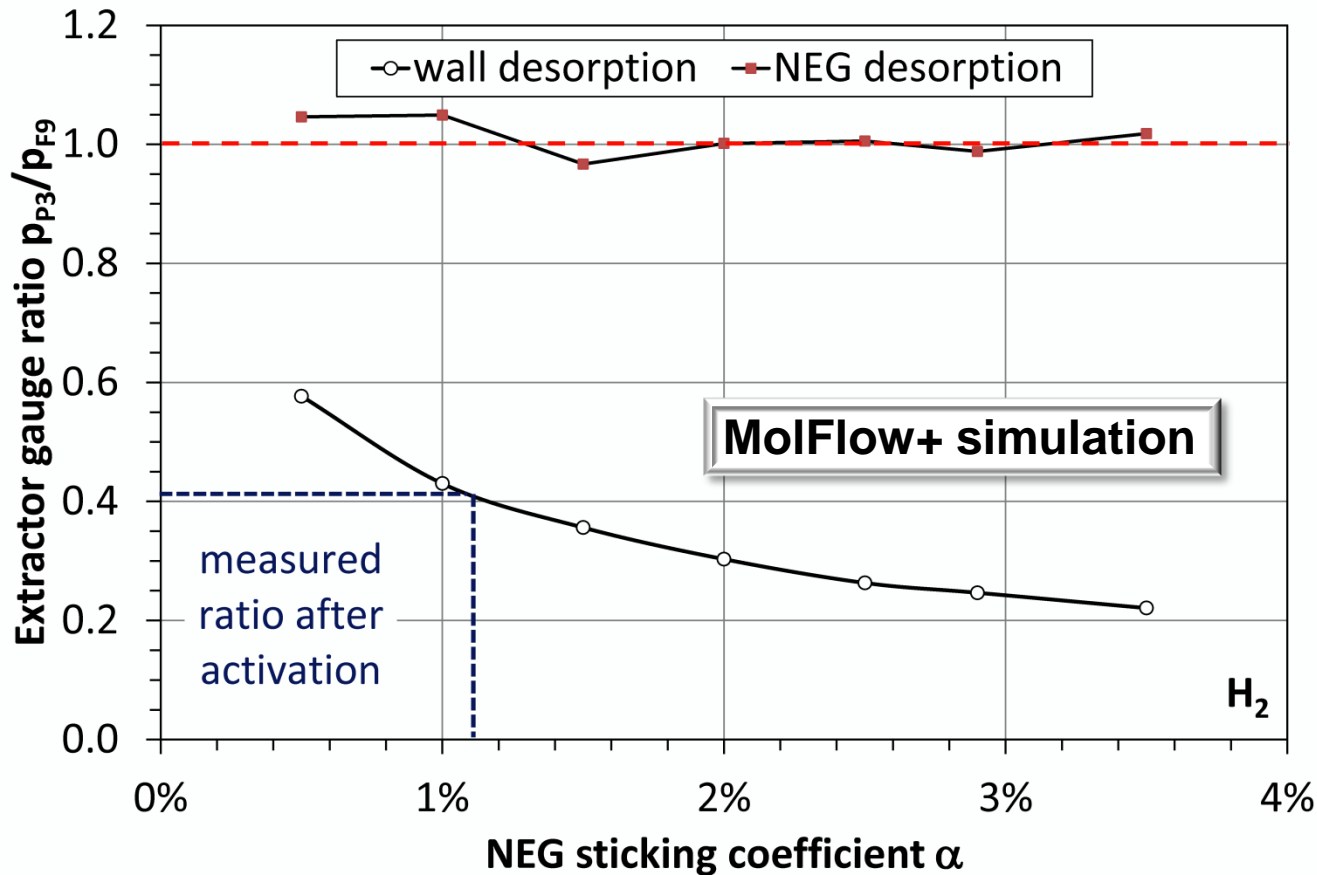
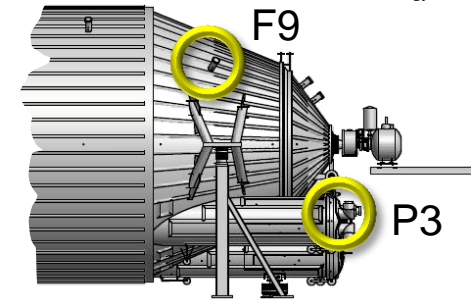

# NEG activation

## Indicator for NEG activation:

- pressure ratio between vessel and pump port
- first indication for NEG pumping at 200°C

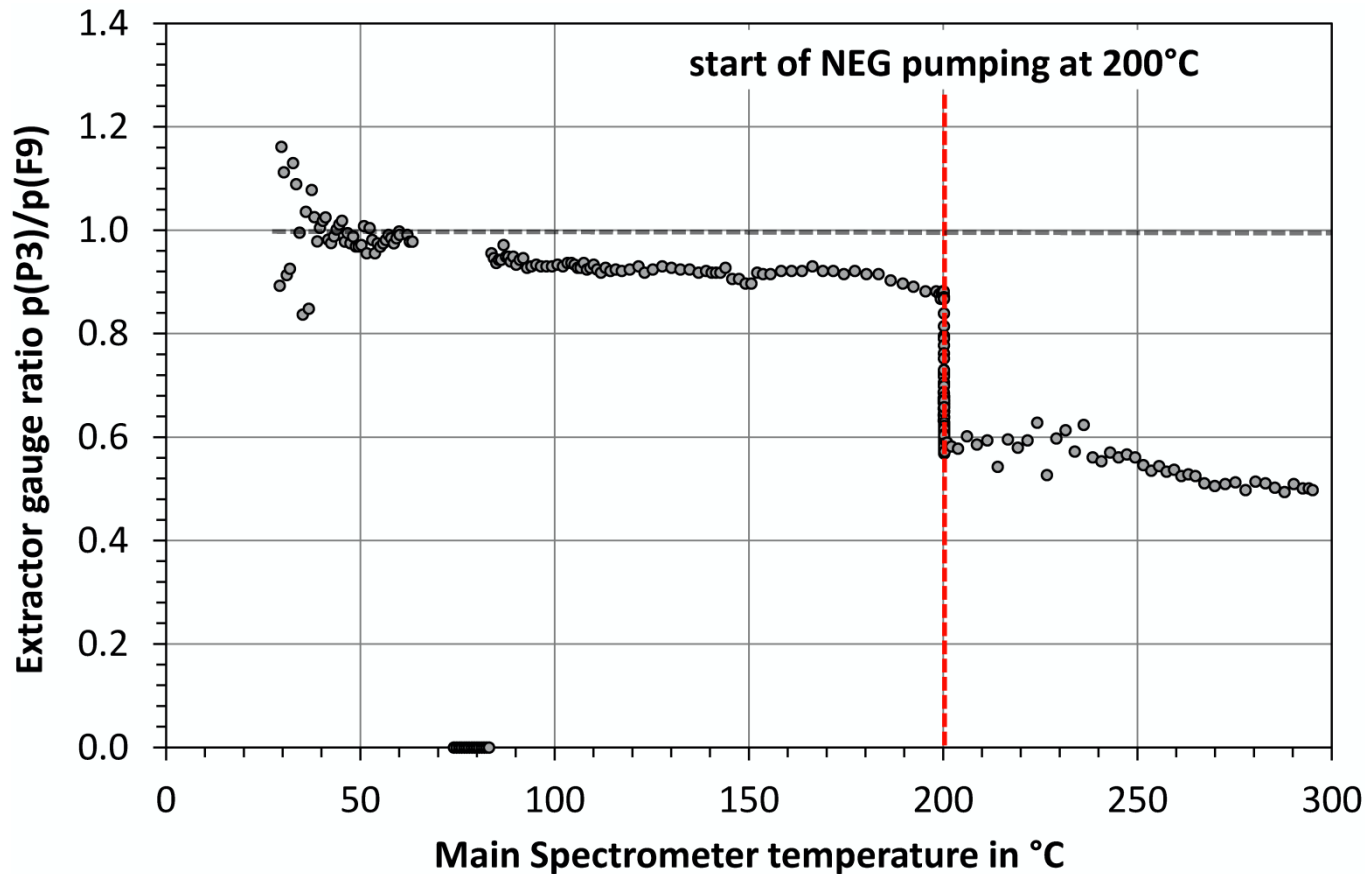
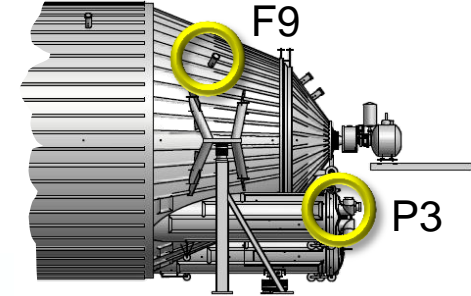

# NEG activation

## Indicator for NEG activation:

- pressure ratio between vessel and pump port
- after baking:  $p_{P3}/p_{F9} = 0.41 \rightarrow S_{NEG} \approx 290 \text{ m}^3/\text{s}$

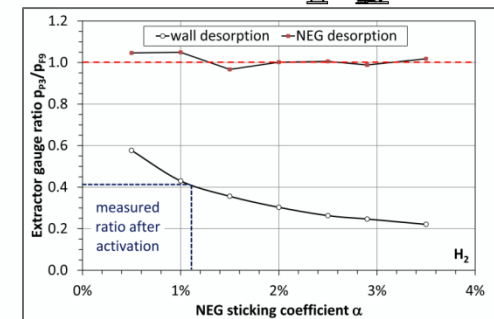
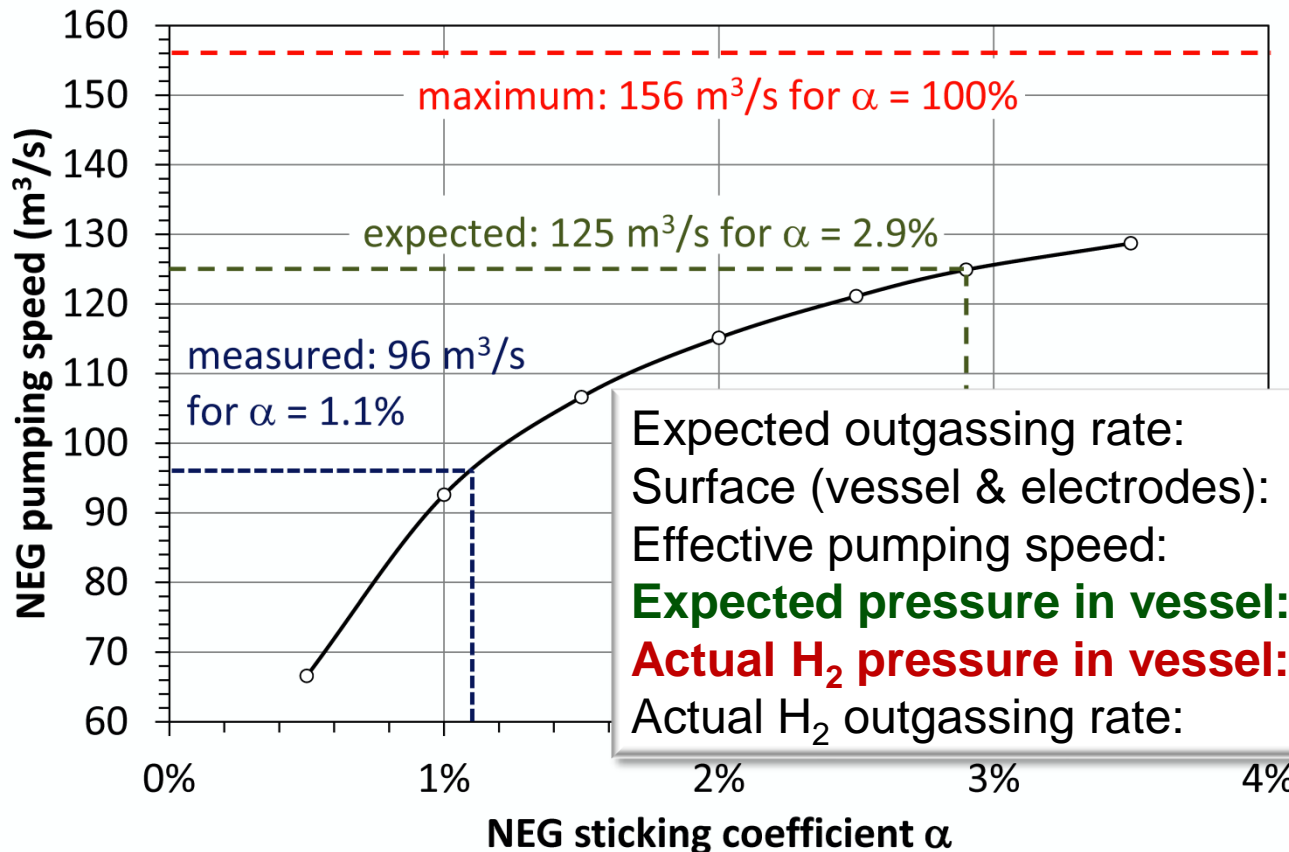
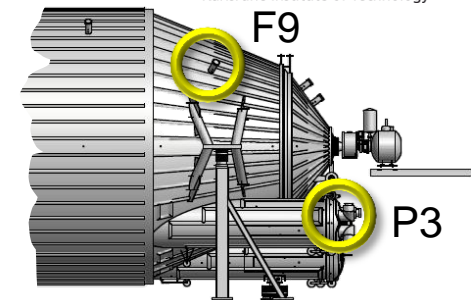

Expected outgassing rate:	$10^{-12} \text{ mbar} \cdot \ell/\text{s} \cdot \text{cm}^2$
Surface (vessel & electrodes):	$1240 \text{ m}^2$
Effective pumping speed:	$375 \text{ m}^3/\text{s}$
<b>Expected pressure in vessel:</b>	<b><math>3.3 \cdot 10^{-11} \text{ mbar}</math></b>
<b>Actual H<sub>2</sub> pressure in vessel:</b>	<b><math>5.7 \cdot 10^{-11} \text{ mbar}</math></b>
Actual H <sub>2</sub> outgassing rate:	$1.4 \cdot 10^{-12} \text{ mbar} \cdot \ell/\text{s} \cdot \text{cm}^2$

# Coupling of Spectrometer and Detector

- Detector de-coupled during bake-out
- Requires valve inside magnet bore
- O-ring partly slipped out during baking
- **Challenge:** attach detector without saturation of the activated NEG-pump

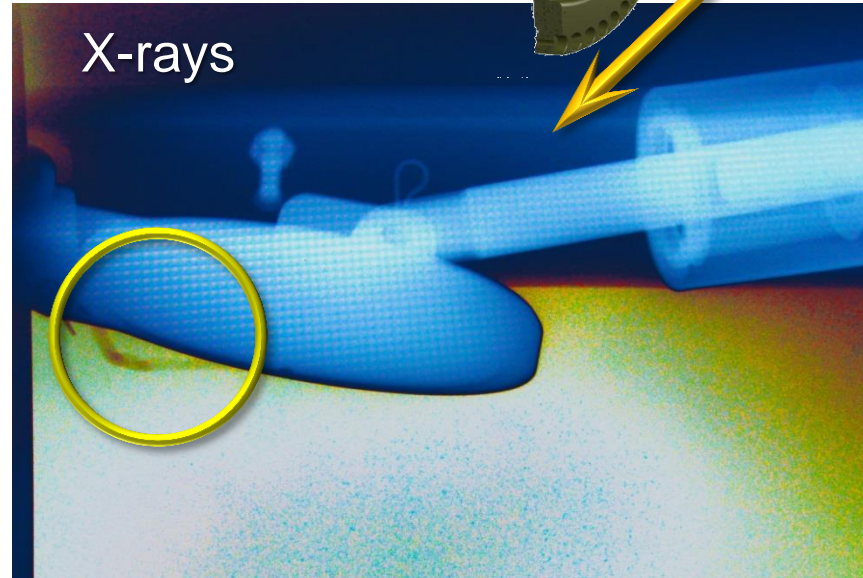
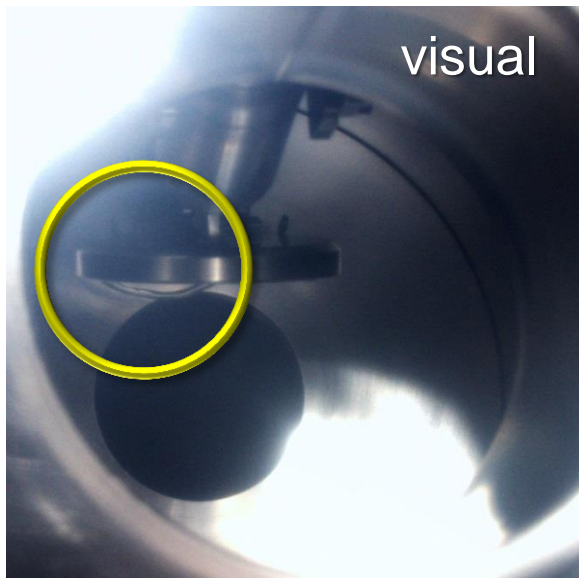
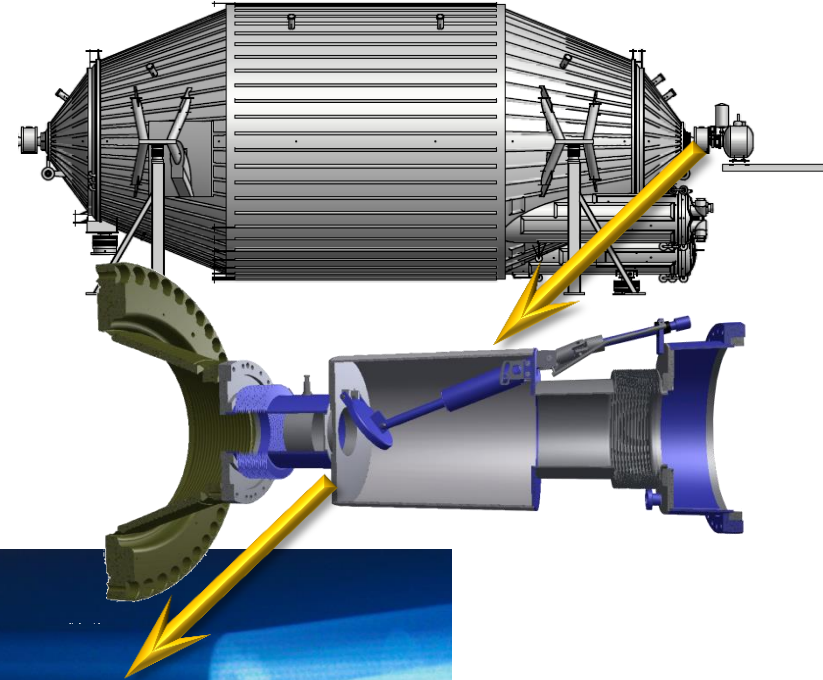

# Coupling of Spectrometer and Detector

- **Solution:** replacing the O-ring under inert gas atmosphere (Ar)
- Gas quality N9.0 required to prevent contamination of NEG

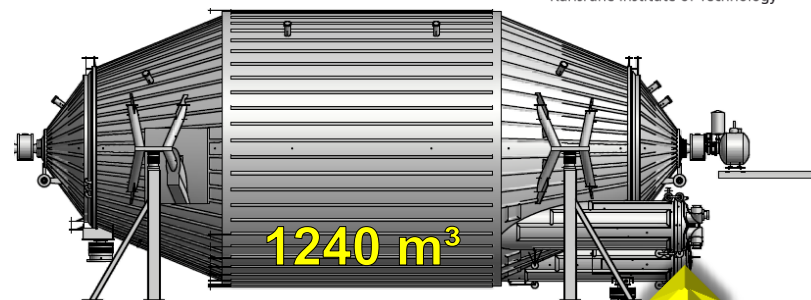

Ar 9.0



144 bottles Argon N6.0



- ☑ O-ring exchanged in Ar atmosphere
- ☑ beam-line valve now leak tight
- ☑ detector section attached

# Vacuum status after venting with argon

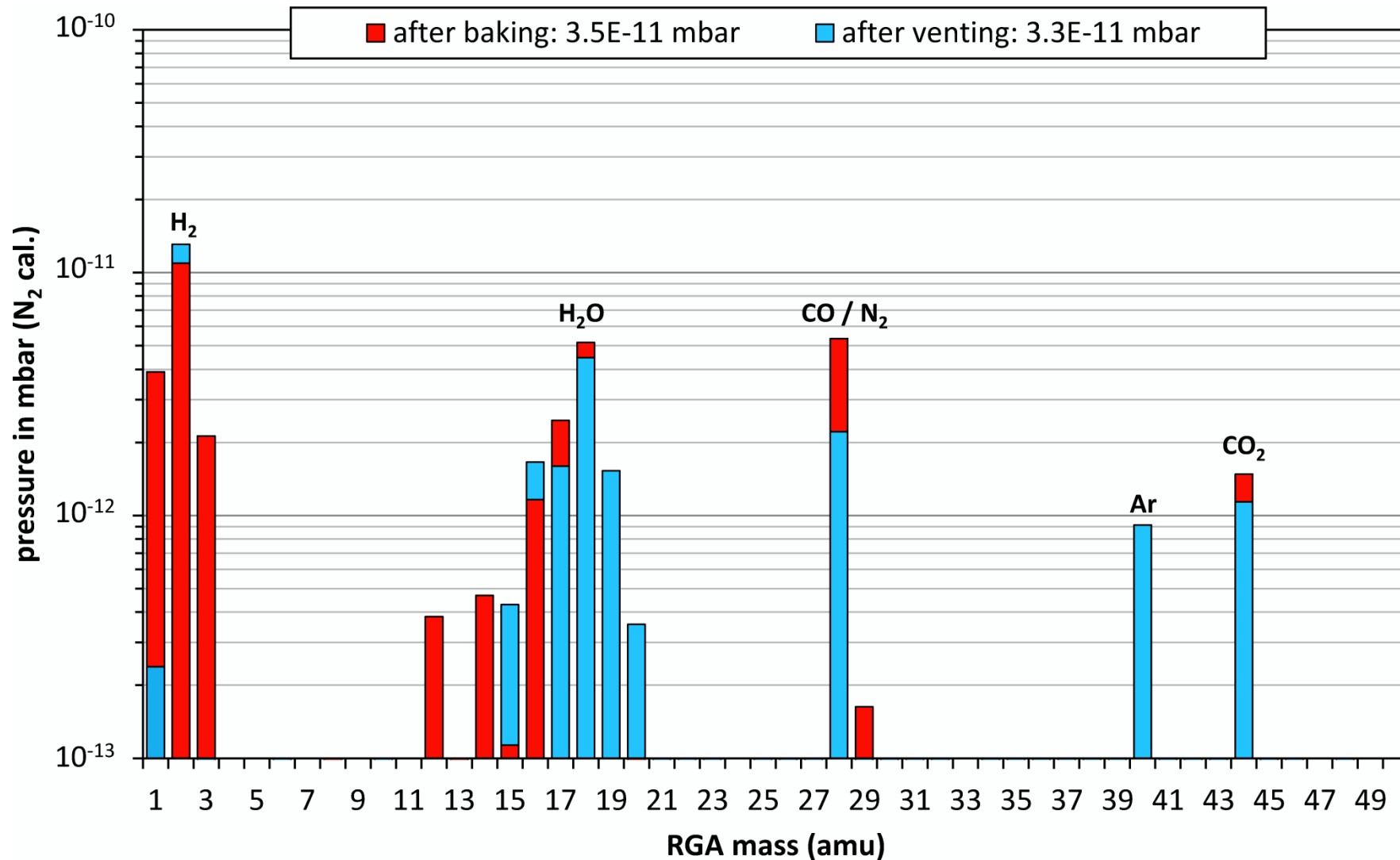



# KATRIN Schedule

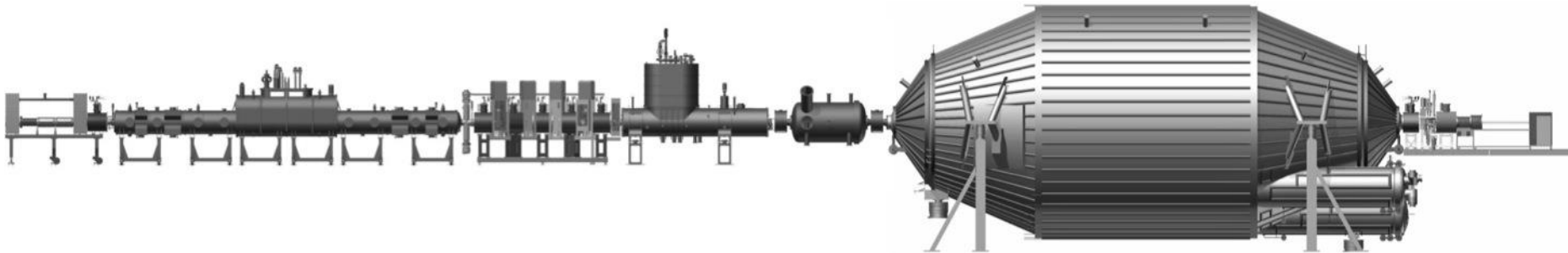

- spectrometer upgrade for low background (0.01 cps) Q1/2015
- tritium retention units DPS and CPS functional Q2/2015
- tritium source WGTS final mounting completed mid-2015
- spectrometer upgrade completed Q3/2015
- all source elements & tritium loops integrated Q4/2015
- first tritium in source, ramp up to nominal  $\rho d$  Q1-Q2/2016
- **first tritium data with entire beam line mid-2016**

# Conclusions

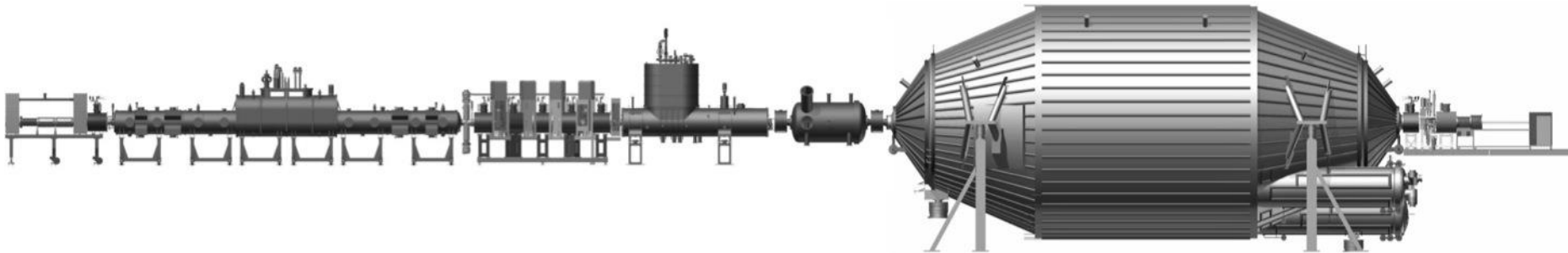

- Source and Transport Section still under construction
- Spectrometer and Detector Section commissioned
- Various smaller experiments investigate specific questions
  - TMPs in magnetic fields
  - Tritium compatibility of TMPs
  - Outgassing rates
  - ...

# Thank you for your attention



# Backup slides

# The KATRIN Setup - Overview

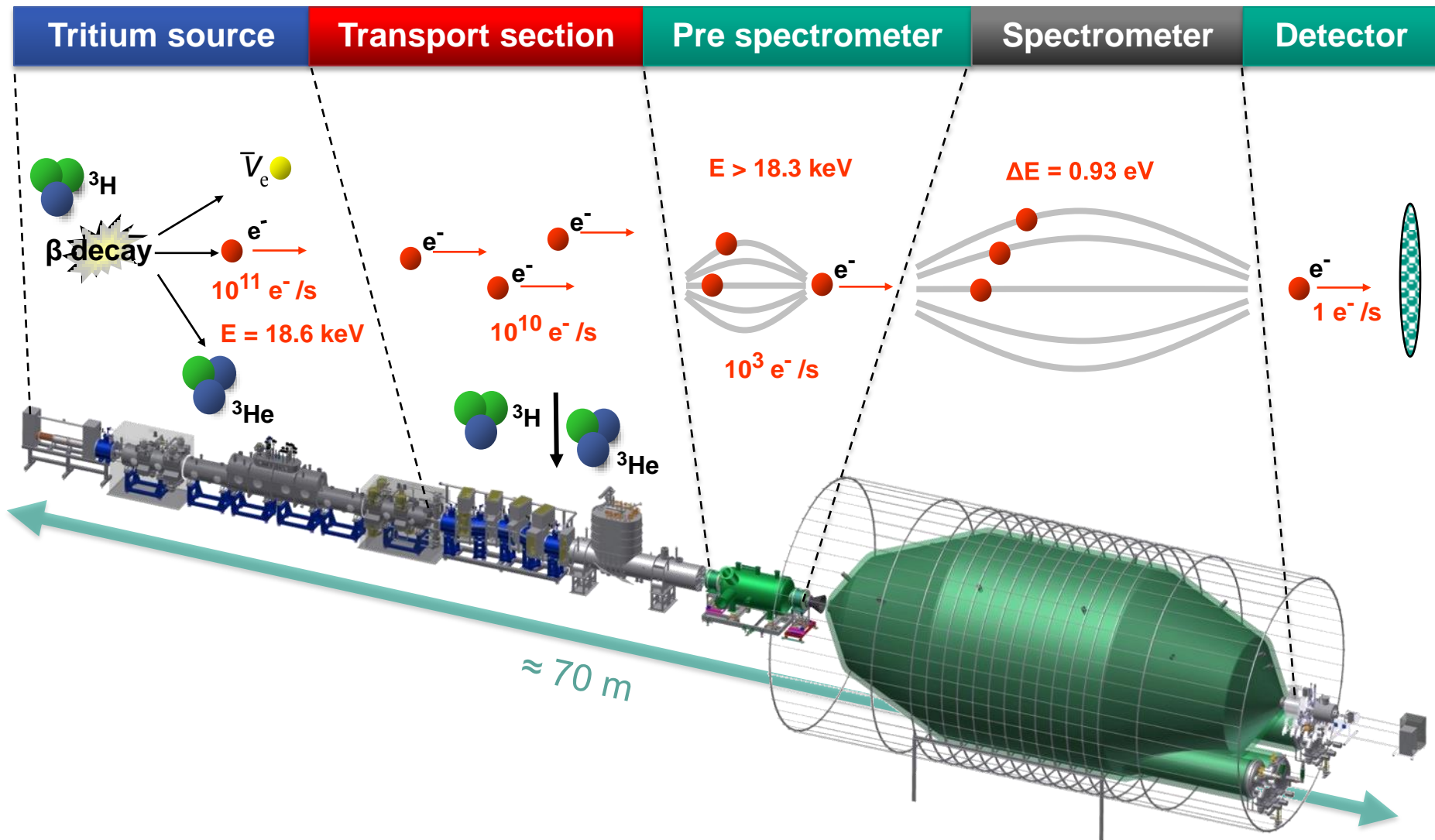

# KATRIN experiment – overview

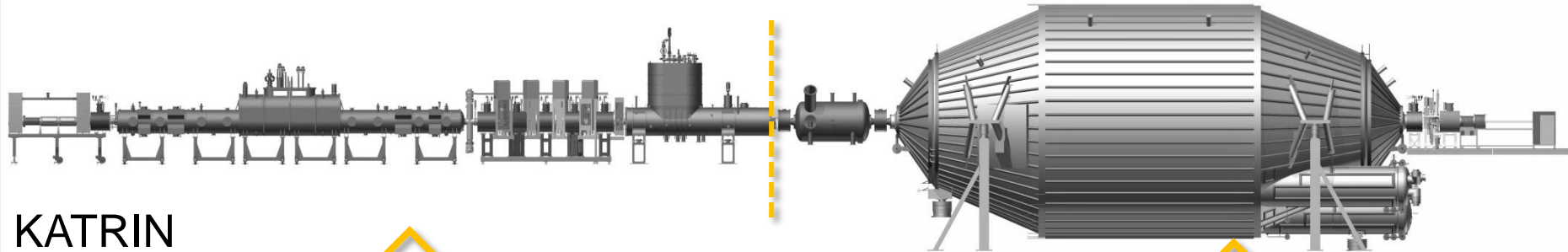

KATRIN  
(2015)



large tritium throughput

~ **10 kg/a**



ITER  
(2027)

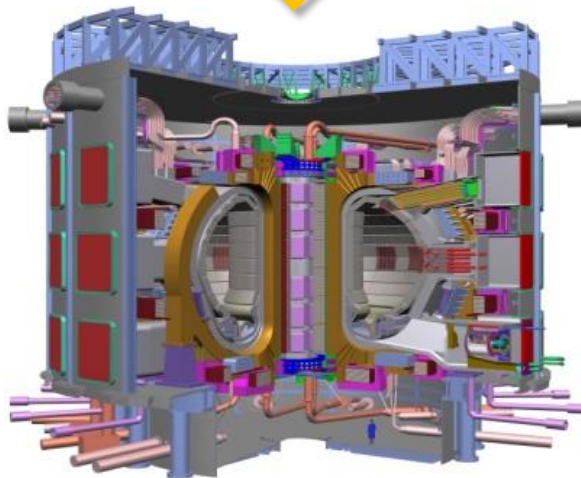

**1240 m<sup>3</sup>**



one of largest UHV-  
recipient (<10<sup>-11</sup> mbar)

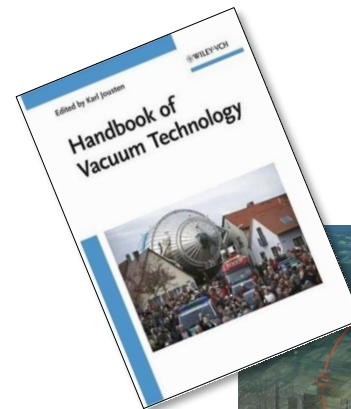

LHC  
154 m<sup>3</sup>

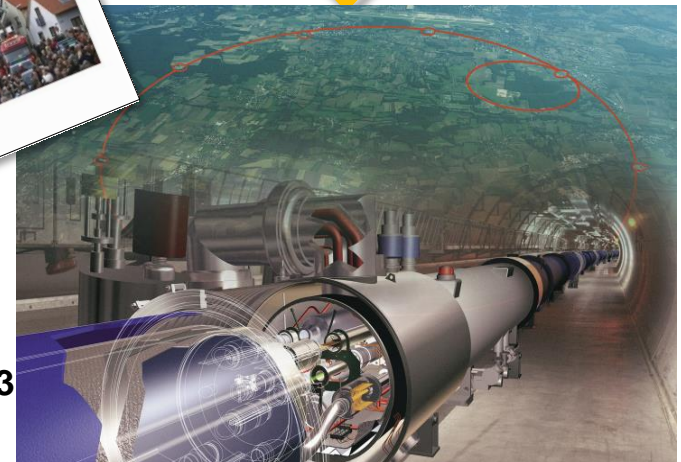

# DPS 2-F – differential pumping section

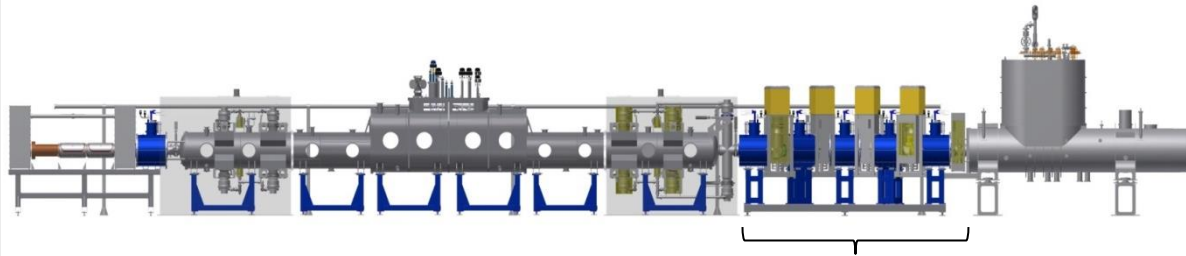

- **DPS:** active differential pumping by 4 main TMPs - retention factor  $10^5$

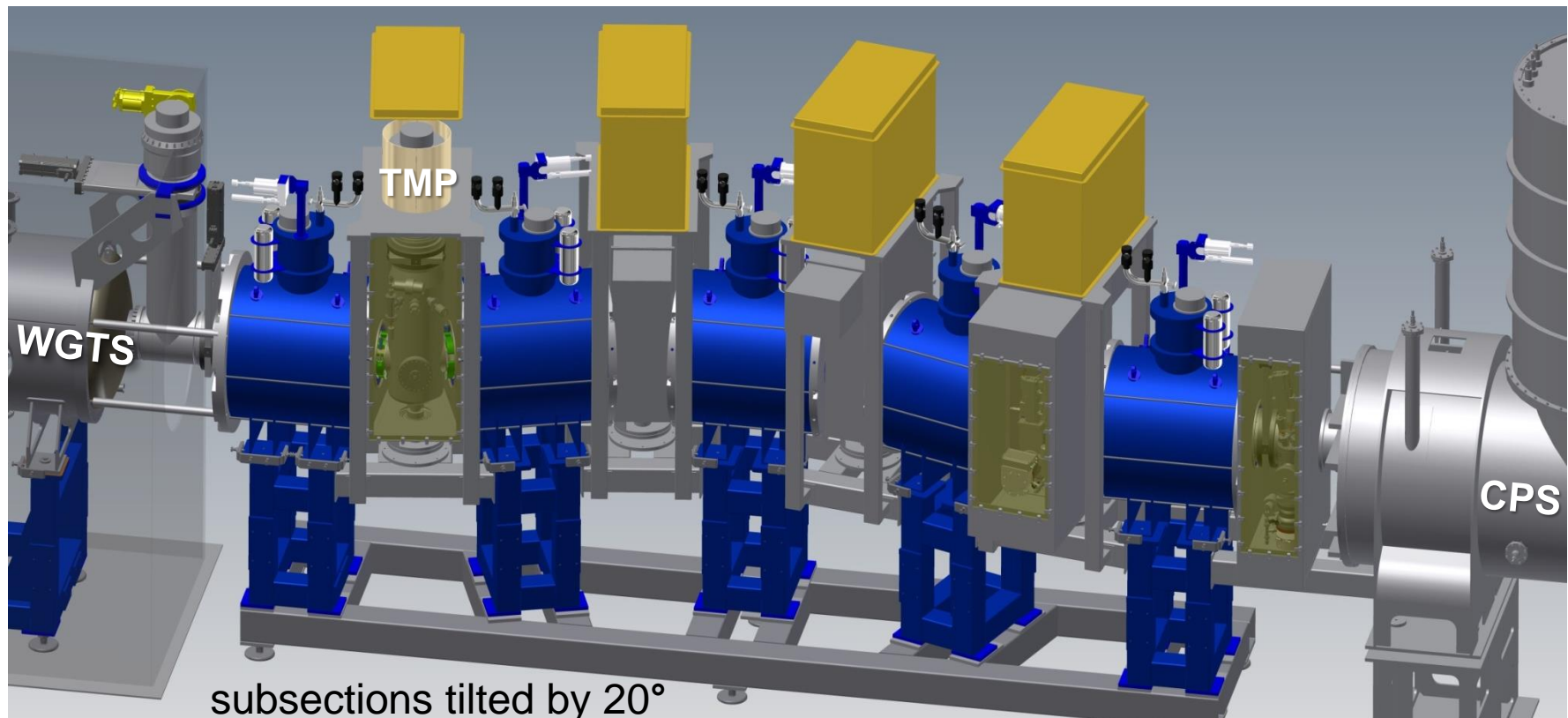

# CPS – cryogenic pumping section

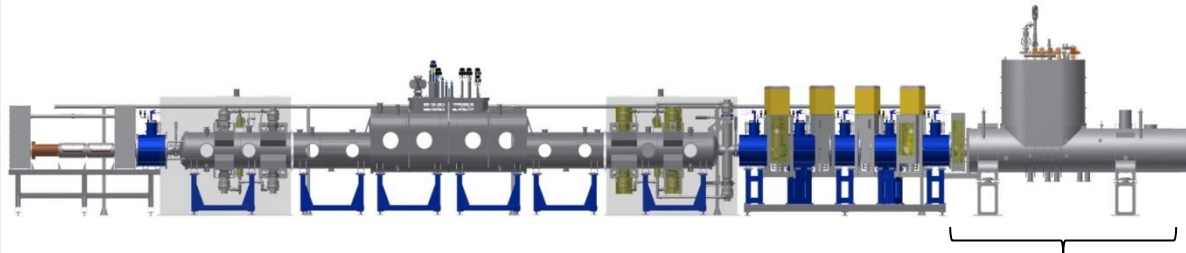

## ■ CPS: passive cryotrap

### cryogenic pumping

- 3 K beam tubes with Ar frost
- tritium retention factor  $> 10^7$

### adiabatic guiding of electrons

- 7 s.c. solenoids ( $B = 5.6$  T)

### Port instrumentation

- vertical access port for condensed  $^{83m}\text{Kr}$  source
- horizontal port for monitoring

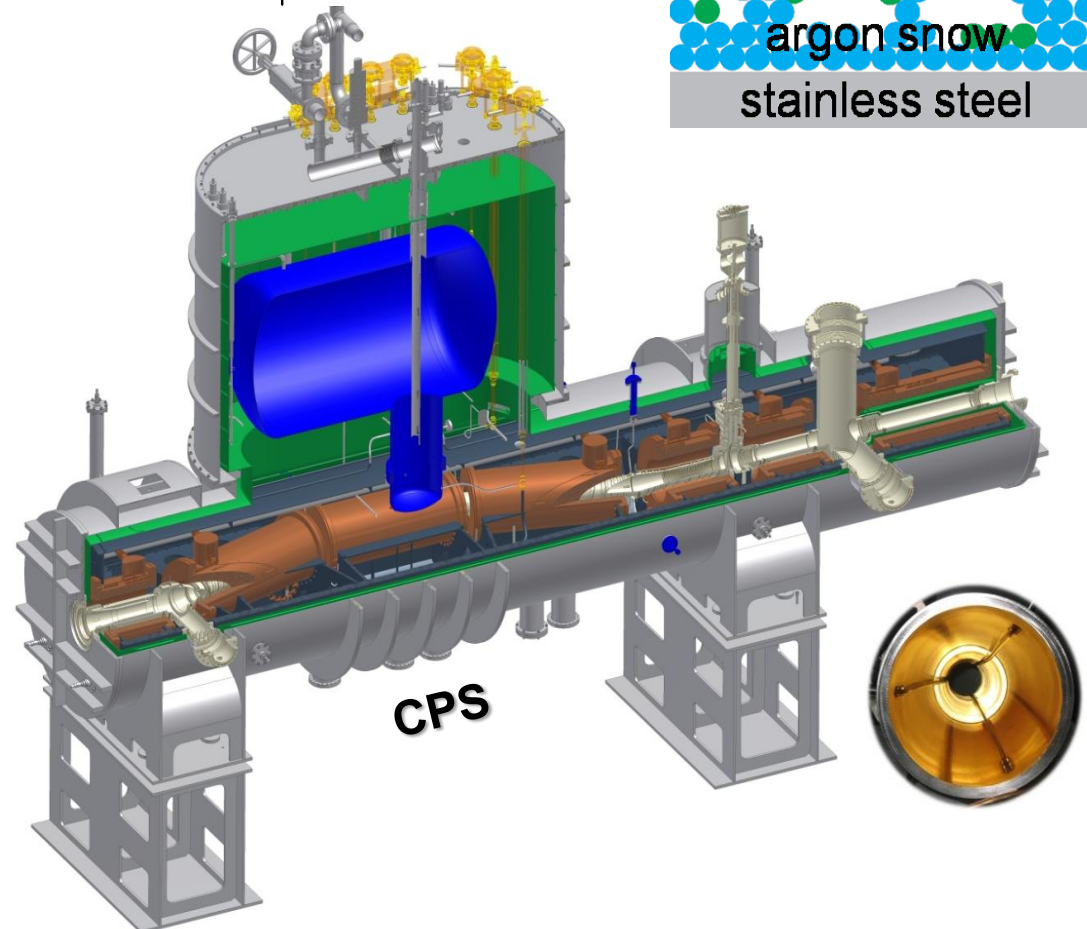
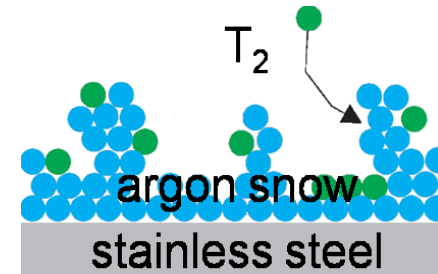



# The MAC-E Filter

A. Picard et al., NIM B 63 (1992)

Magnetic Adiabatic Collimation  
with Electrostatic Filter

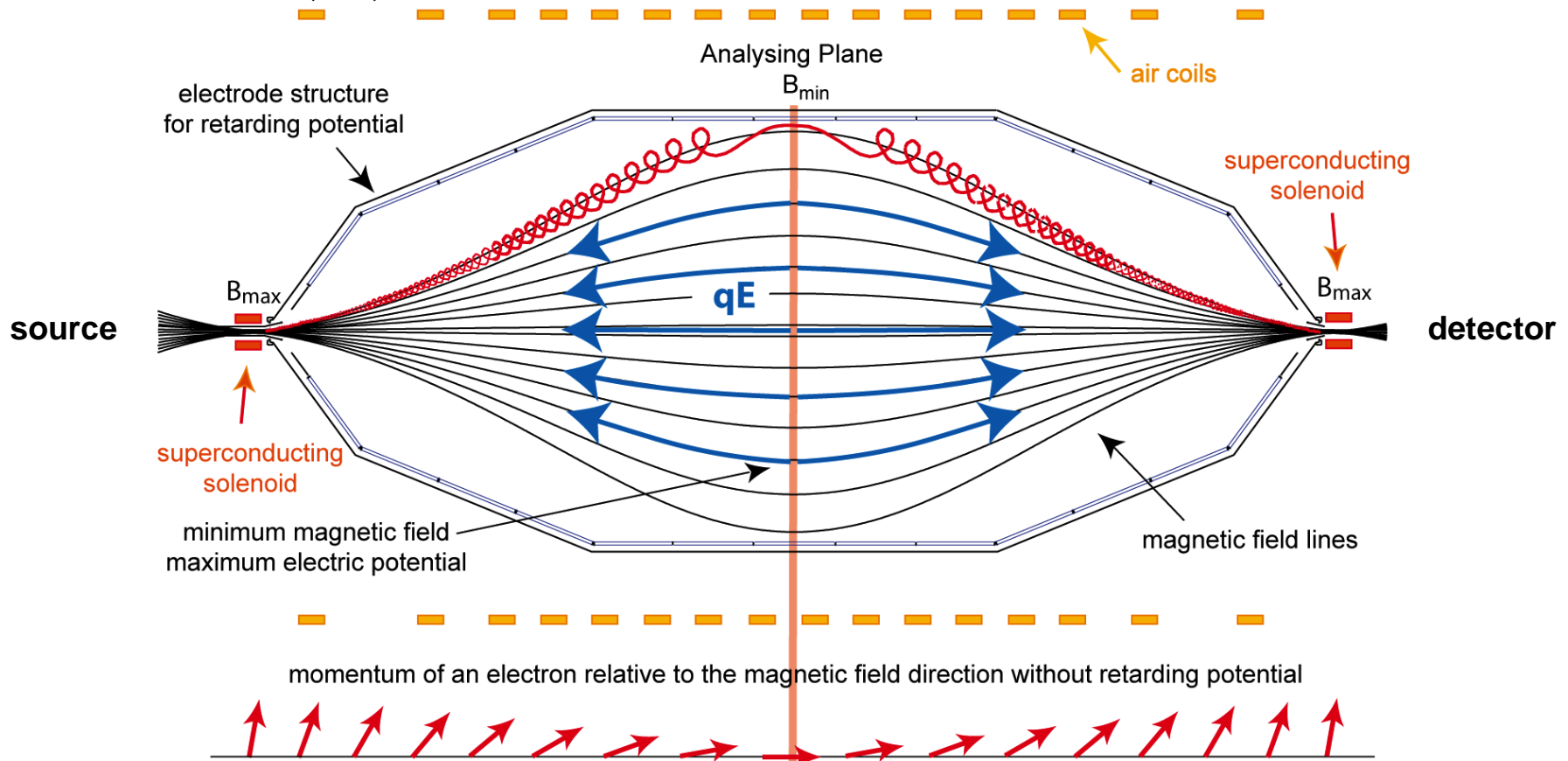

- **collimation:**  $\mu = E_{\perp} / B = \text{const}, \rightarrow E_{\perp} \rightarrow E_{\parallel}$  for  $B = 6 \text{ T} \rightarrow 3 \text{ mT}$
- **energy analysis:** transmission condition:  $E_{\parallel} > eU_0$  (retarding potential)
- **energy resolution:**  $\Delta E = E \cdot B_{\min} / B_{\max} = 18.6 \text{ keV} \cdot 0.3 \text{ mT} / 6 \text{ T} = 0.93 \text{ eV}$

# 2013: Spectrometer Commissioning

## ■ Vacuum conditioning for the MAC-E-filter test measurements

- Plan: baking of the M.S. at 350°C (cleaning and activation of NEG)
- Goal: reach UHV conditions with  $p \approx 10^{-11}$  mbar
- Bake-out in January 2013

## ■ Problems during bake-out (partly solved)

- Short circuit between current leads to electrodes @ 200°C – 300°C
  - Reduced baking temperature (300°C) to avoid further damage
- Leakage in CF flange at 50°C
  - Differentially pumped vacuum sleeve
  - Another leakage after Ar venting
- Leakage in beam-line valve
  - Ar venting for repair

## ■ Detector and e-gun connected

## ■ Start of MAC-E-filter tests

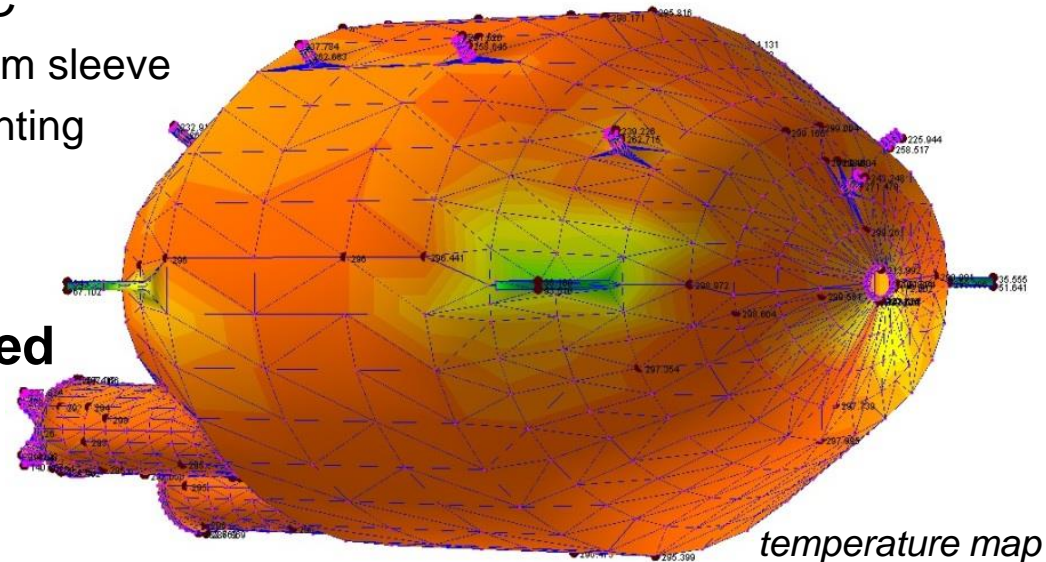

## detailed transmission and background studies

- sharpest transmission function ever measured with MAC-E filter
- background from  $^{219}\text{Rn}/^{220}\text{Rn}$  emanation eliminated

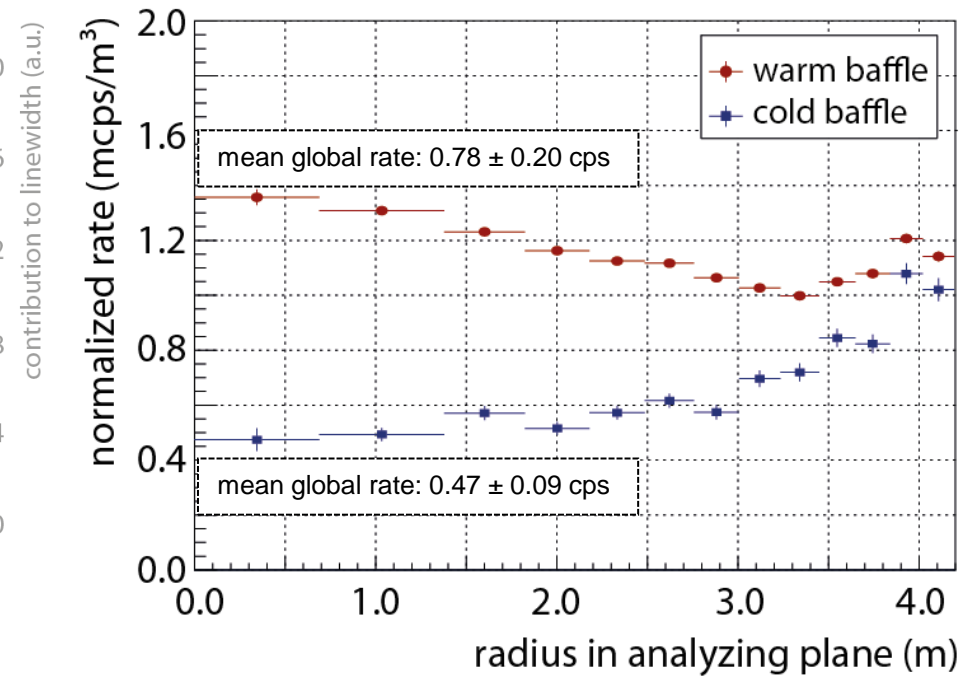
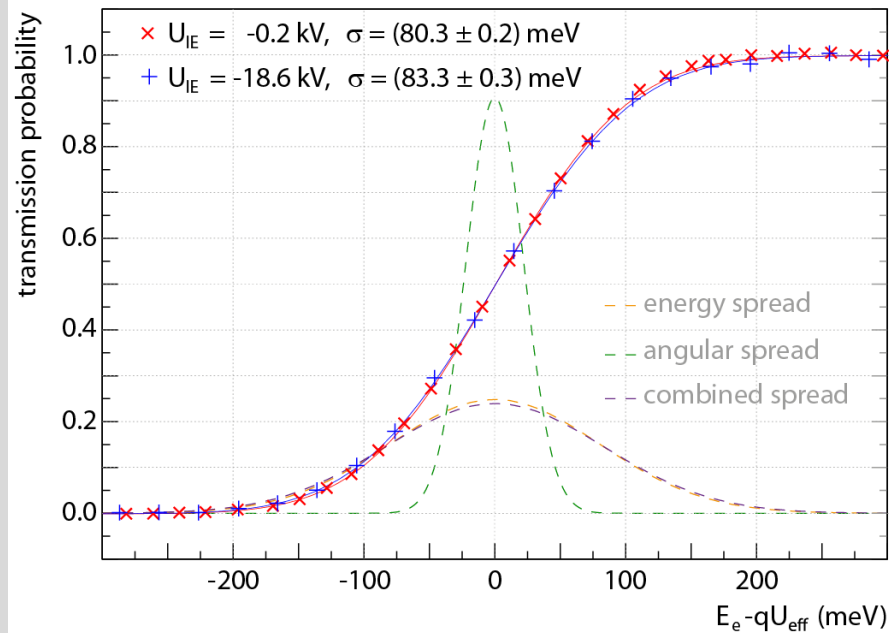

- will be improved during 2014 commissioning runs

# Results on the Radon Induced Background

## Measurements with cold baffles and high voltage

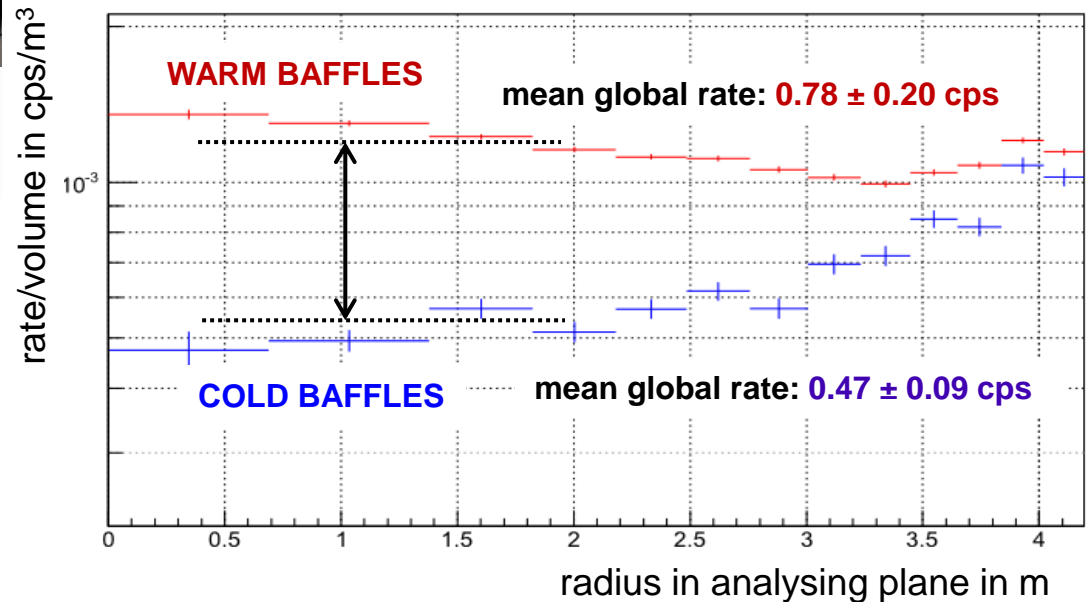
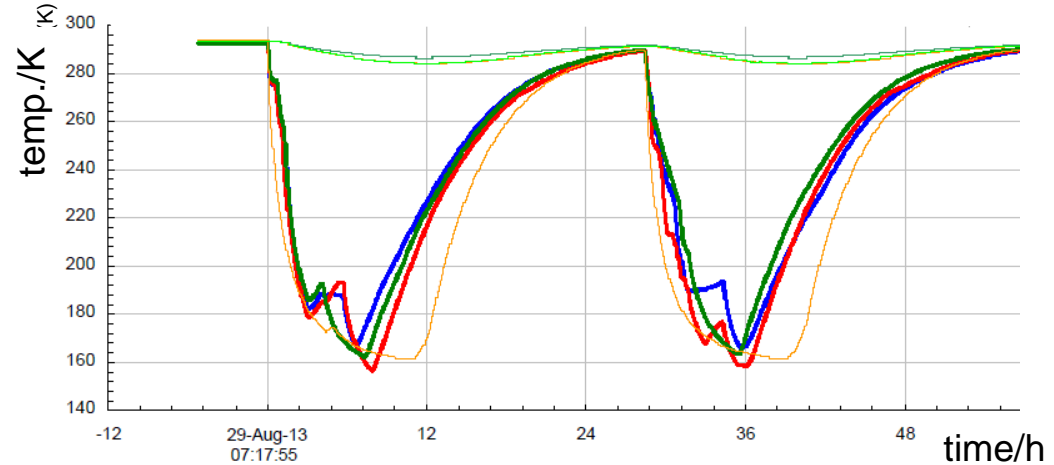
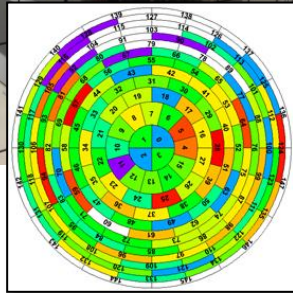
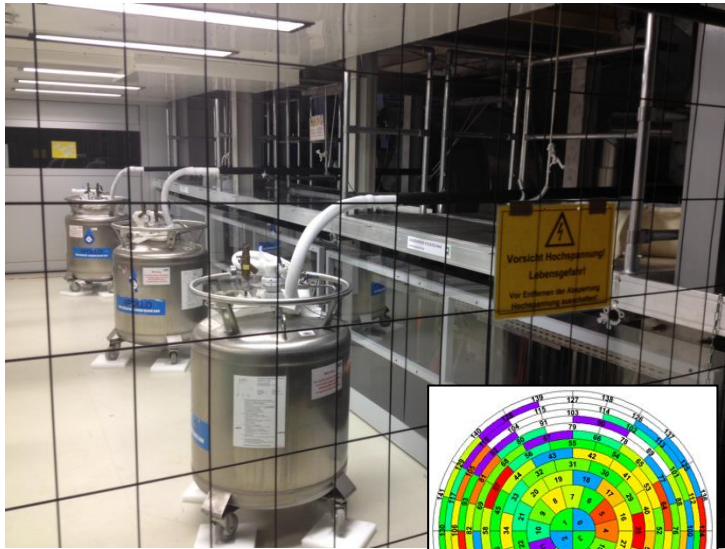

- Two short measurements
- Background strongly reduced
- Proof of principle: baffles work as expected
- Long-term performance will be tested in 2014/2015

# Vacuum scheme of the Main Spectrometer

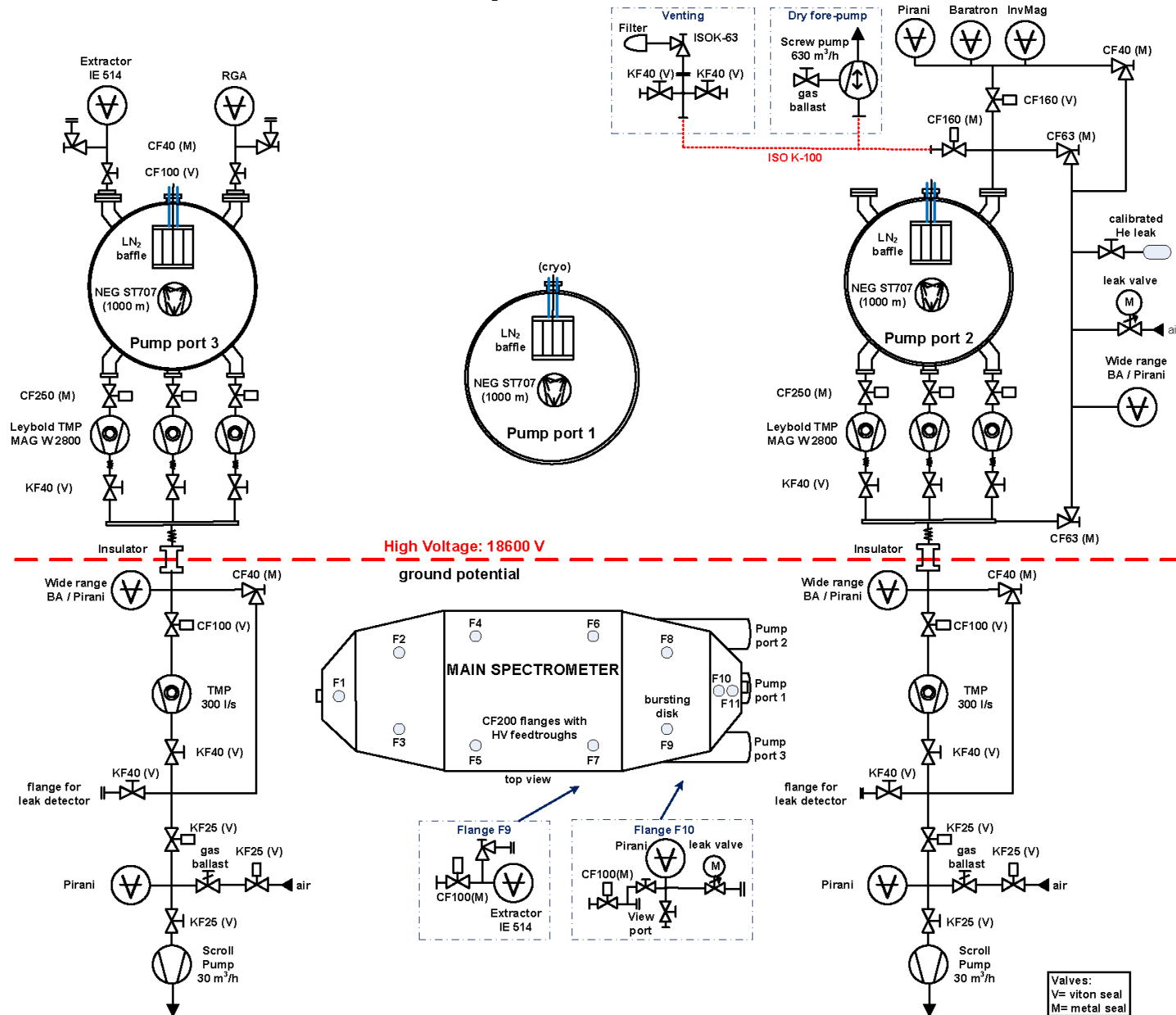

# KATRIN Main Spectrometer

Spectrometer itself is a source of background

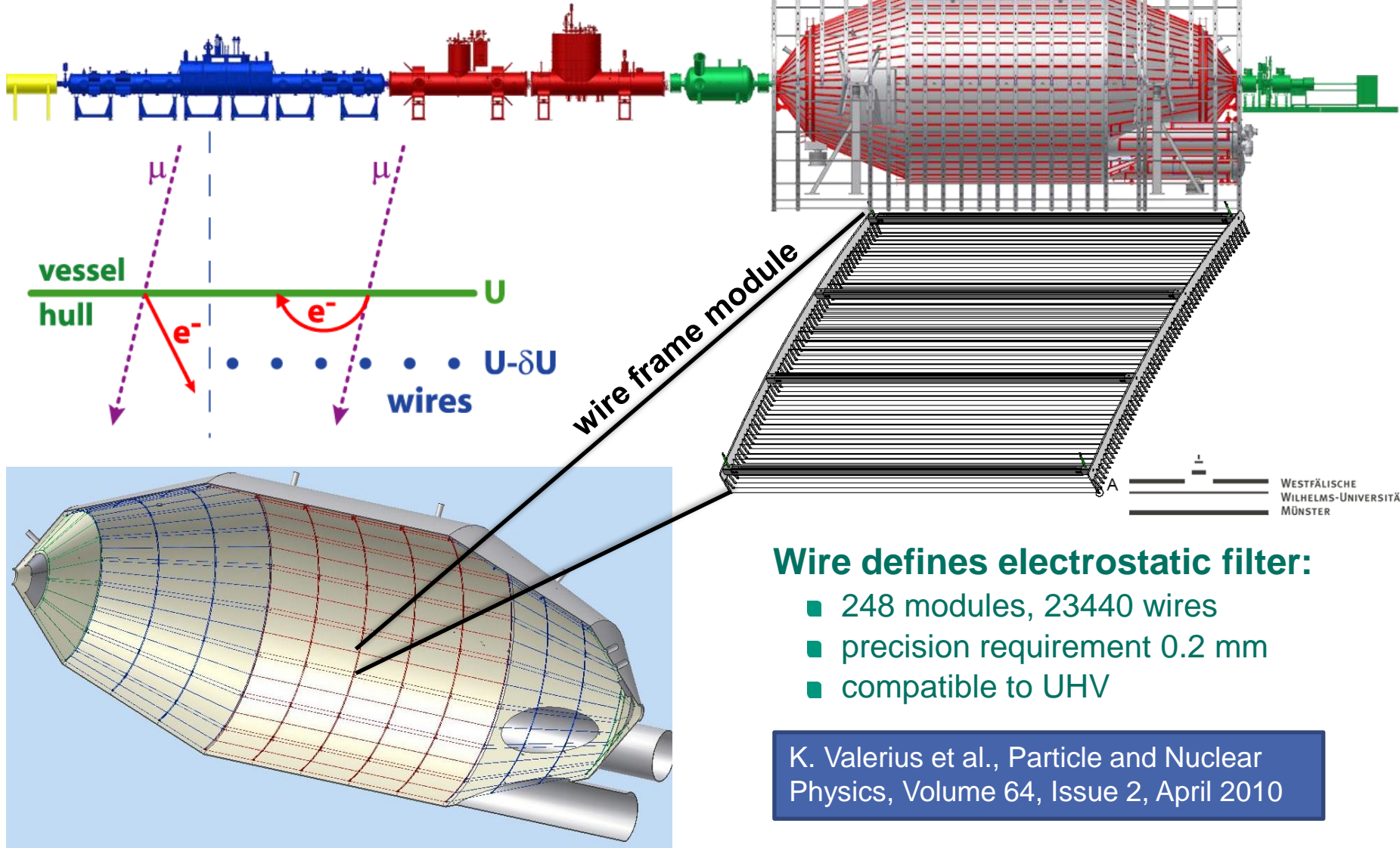

## Wire defines electrostatic filter:

- 248 modules, 23440 wires
- precision requirement 0.2 mm
- compatible to UHV

K. Valerius et al., Particle and Nuclear Physics, Volume 64, Issue 2, April 2010

# KATRIN Main Spectrometer

Component	Material	Temp.	Surface
Main Spectrometer vacuum vessel	316LN	20°C	690.0 m <sup>2</sup>
Wires (23440 wires with a total length of 42400 m)	316L	20°C	33.6 m <sup>2</sup>
Electrode frames (248 modules)	316L	20°C	436.8 m <sup>2</sup>
Electrode rail system	316LN	20°C	58.0 m <sup>2</sup>
Feedthrough flanges	316LN	20°C	2.0 m <sup>2</sup>
Small components (frame NEG-pumps, etc.)	316L	20°C	1.5 m <sup>2</sup>
<b>Σ stainless steel</b>	<b>316L(N)</b>	<b>20°C</b>	<b>1221.9 m<sup>2</sup></b>
<b>Σ ceramic insulators</b>	<b>Al<sub>2</sub>O<sub>3</sub></b>	<b>20°C</b>	<b>5.8 m<sup>2</sup></b>
<b>Σ anti-penning electrodes</b>	<b>Ti</b>	<b>20°C</b>	<b>11.0 m<sup>2</sup></b>
<b>Σ ground electrodes</b>	<b>Al</b>	<b>20°C</b>	<b>1.3 m<sup>2</sup></b>
<b>Σ surfaces at room temperature</b>		<b>20°C</b>	<b>1240 m<sup>2</sup></b>
<b>Σ cryogenic baffles</b>	<b>Cu</b>	<b>77 K</b>	<b>31 m<sup>2</sup></b>
<b>Σ NEG-strips</b>	<b>St707</b>	<b>20°C</b>	<b>180 m<sup>2</sup></b>
<b>Volume Main Spectrometer</b>			<b>1240 m<sup>3</sup></b>

# Simulations of the Main Spectrometer

- simplified model of the main spectrometer created (optimized discretization for Molflow)
- simulate pressure ratio  $p_{P3} / p_{F9}$  of pressure gauges

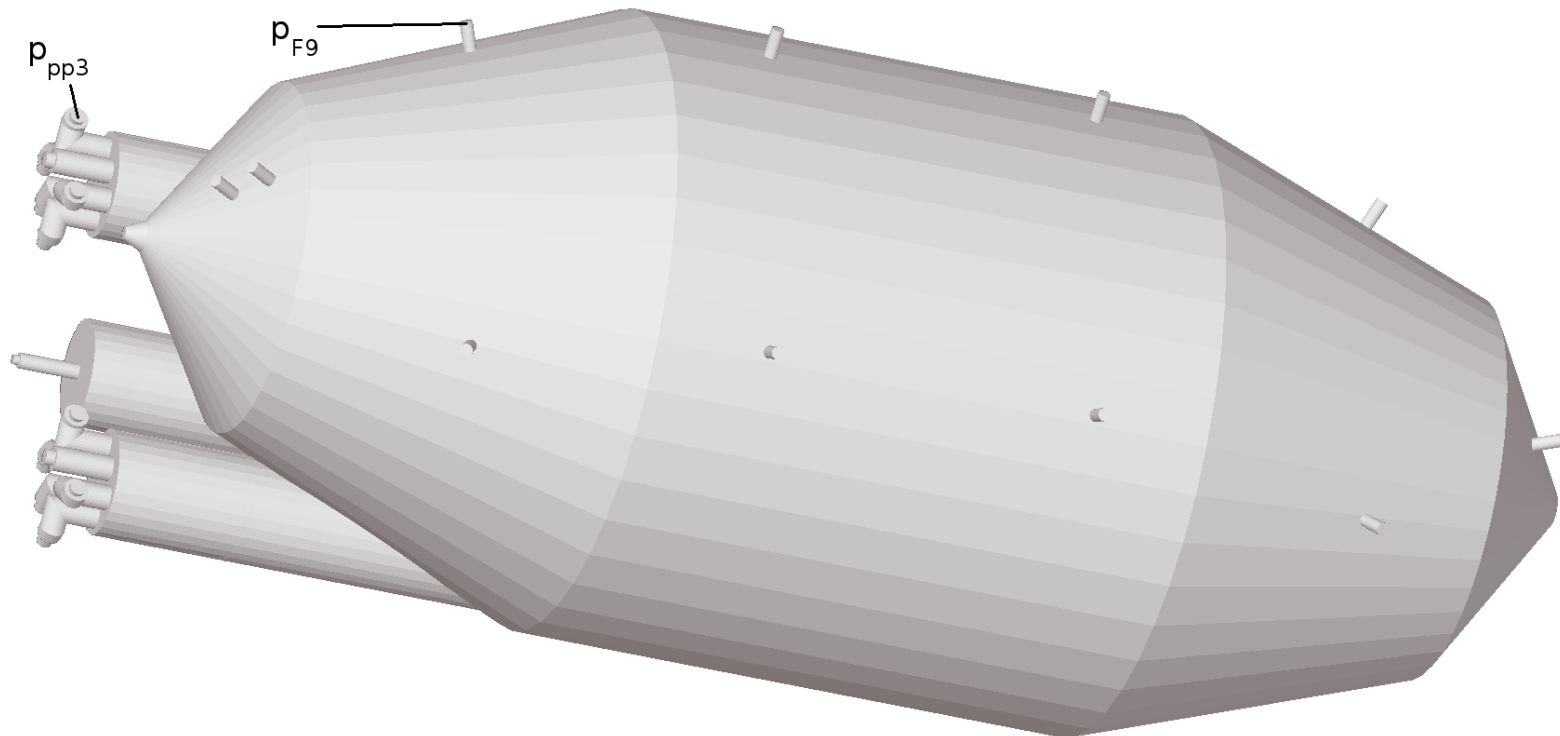



# Simulations of the Main Spectrometer

- **three possible gas sources for hydrogen and radon:**
  - complete stainless steel tank
  - NEG strips in pump ports
  - diagonal virtual area in one pump port (cross section between port and vessel) for determination of pumping speeds
- **three possible pump variations:**
  - NEG pumps hydrogen with  $\alpha_{\text{NEG}}$  between 0.5% and 3.5% (2.9% expected)
  - TMPs for hydrogen or radon with their respective  $\alpha_{\text{TMP}}$
  - baffles with  $\alpha_{\text{baffle}}$  between 0% and 100% for radon
- **aims:**
  - find correlations between  $\alpha_{\text{baffle}}$ ,  $\alpha_{\text{NEG}}$  and pressure ratios
  - simulation of effective pumping speed of NEG, TMPs and baffles
  - comparison with experimental ratios → effective pumping speed
  - simulate radon suppression factor

# Simulation of the Main Spectrometer (MoIFlow+)

## ■ main components:

- CF 200 ports on main vessel
- Baffles
- NEG strips
- Vacuum gauges
- TMPs

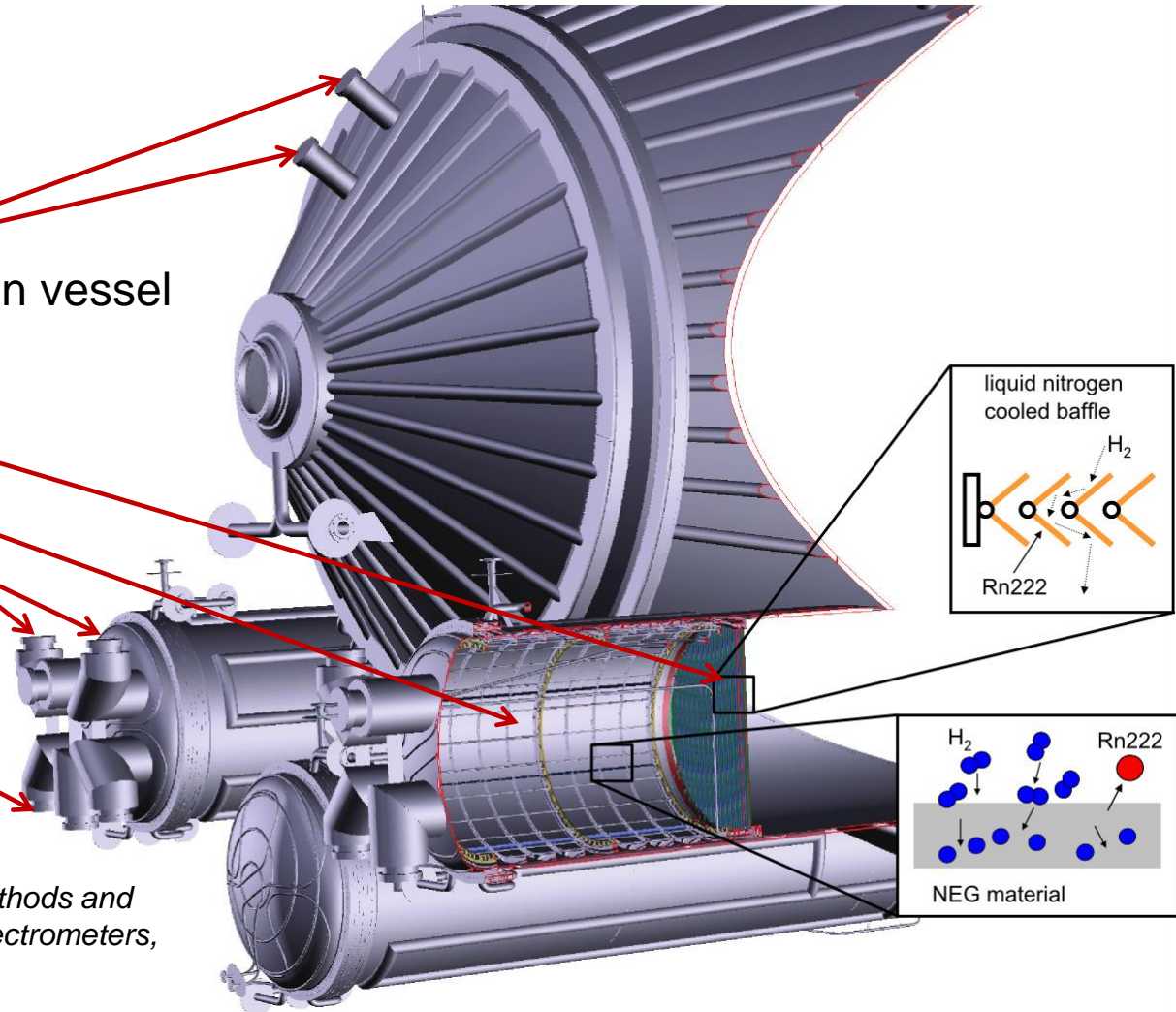

Source:

S. Görhardt: *Background Reduction Methods and Vacuum Technology at the KATRIN spectrometers*, PhD thesis, Karlsruhe 2014

# Simulation of an effective pumping speed

- Simulate pump as surface with an **adsorption probability**  $\alpha$
- Determine **pumping probability**:  $w = N_{ads}/N_{des}$
- Calculate the **effective pumping speed**:  $S(M) = 1/4 \bar{c}_M \cdot A_{port} \cdot w$

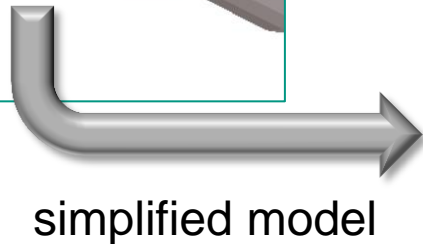
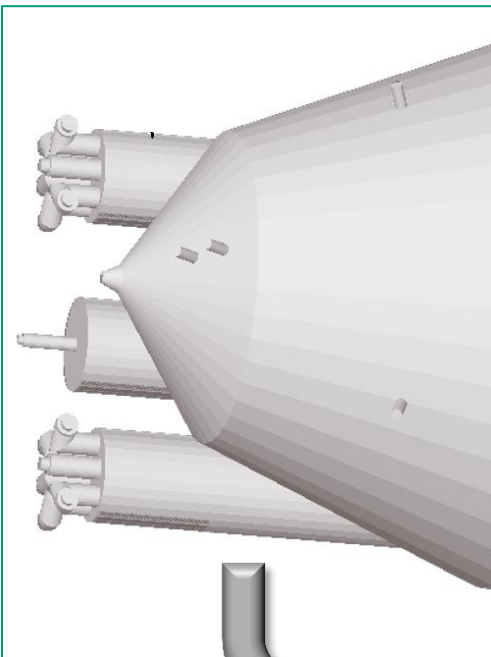

$\bar{c}$  : mean molecular speed for mass  $M$

$$\bar{c} = \sqrt{\frac{8k_B T}{\pi M}}$$

$A_{port}$  : desorption area (virtual area)

$N_{ads}$  : number of adsorptions in pump

$N_{des}$  : total desorption number

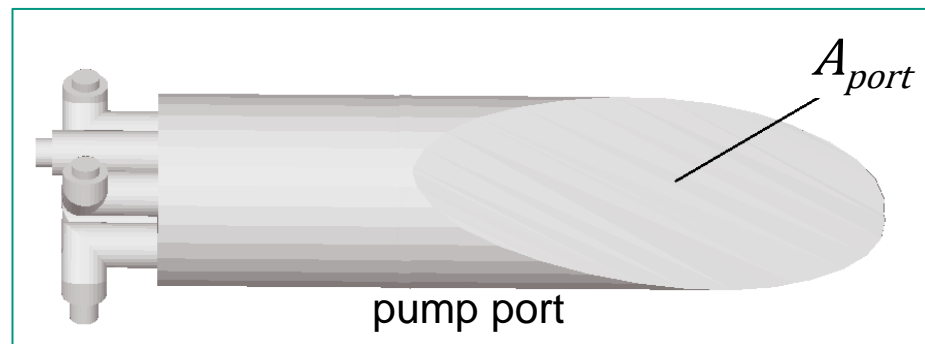

# TMP simulation

- Determine pumping speed of TMP for **mass of gas particle** (Malyshev model)
- Simulate **pumping probability**  $w = N_{ads}/N_{des}$
- **Effective pumping speed:**  $S(M_2) = 1/4 \bar{c}_{M_2} \cdot A_{port} \cdot w$

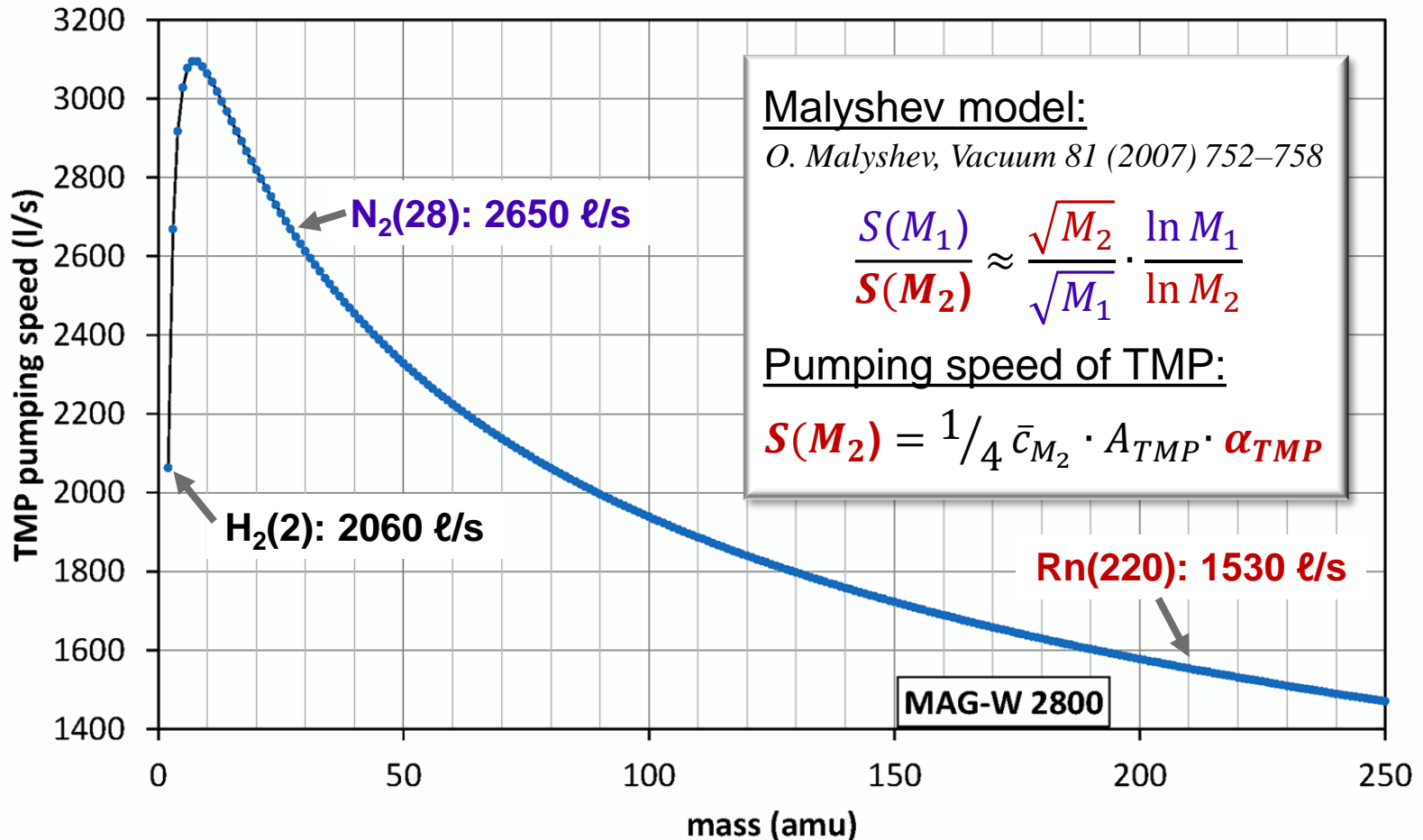

# NEG-pump simulation (without baffle)

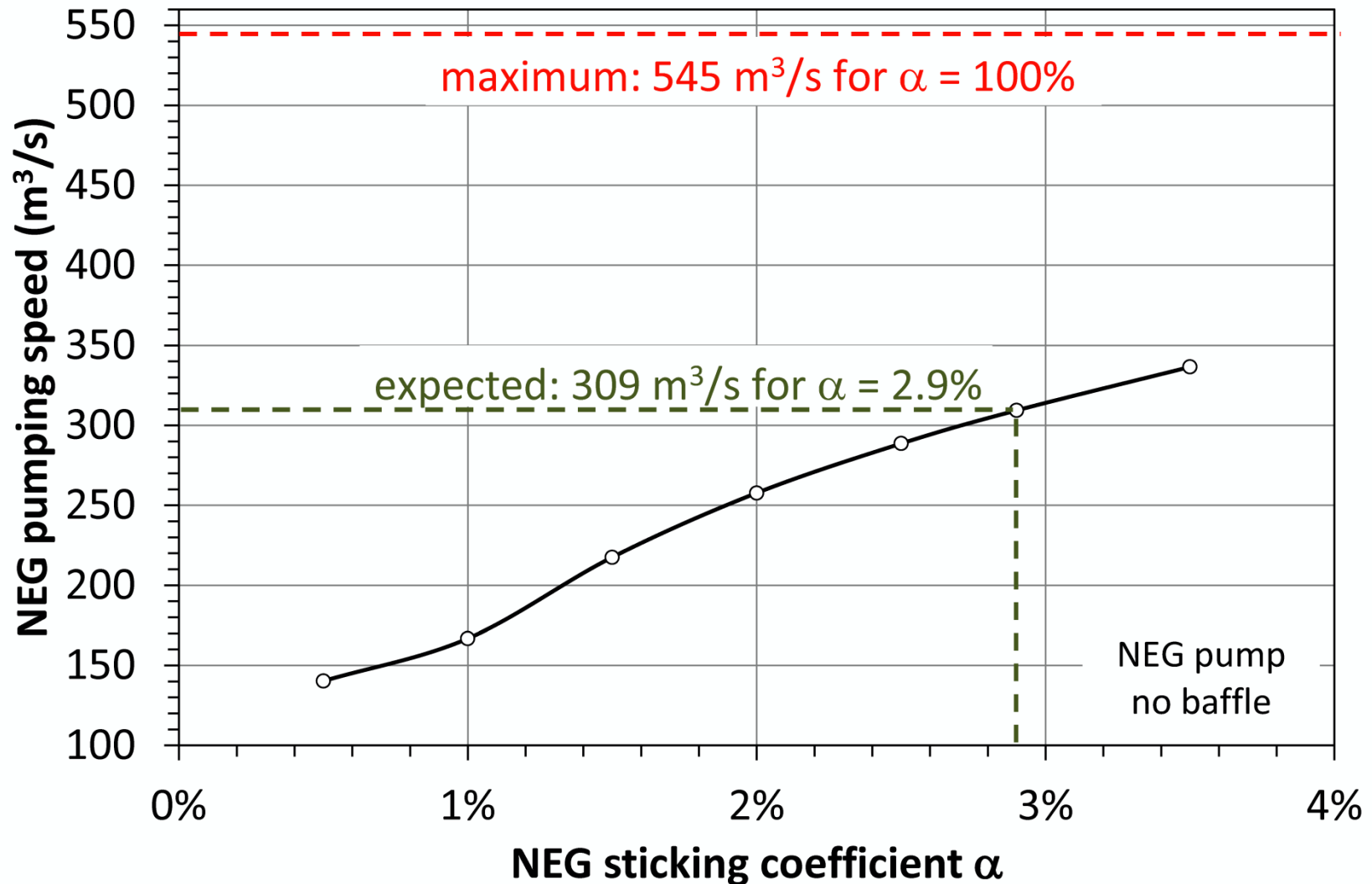

# NEG-pump simulation (with baffle)

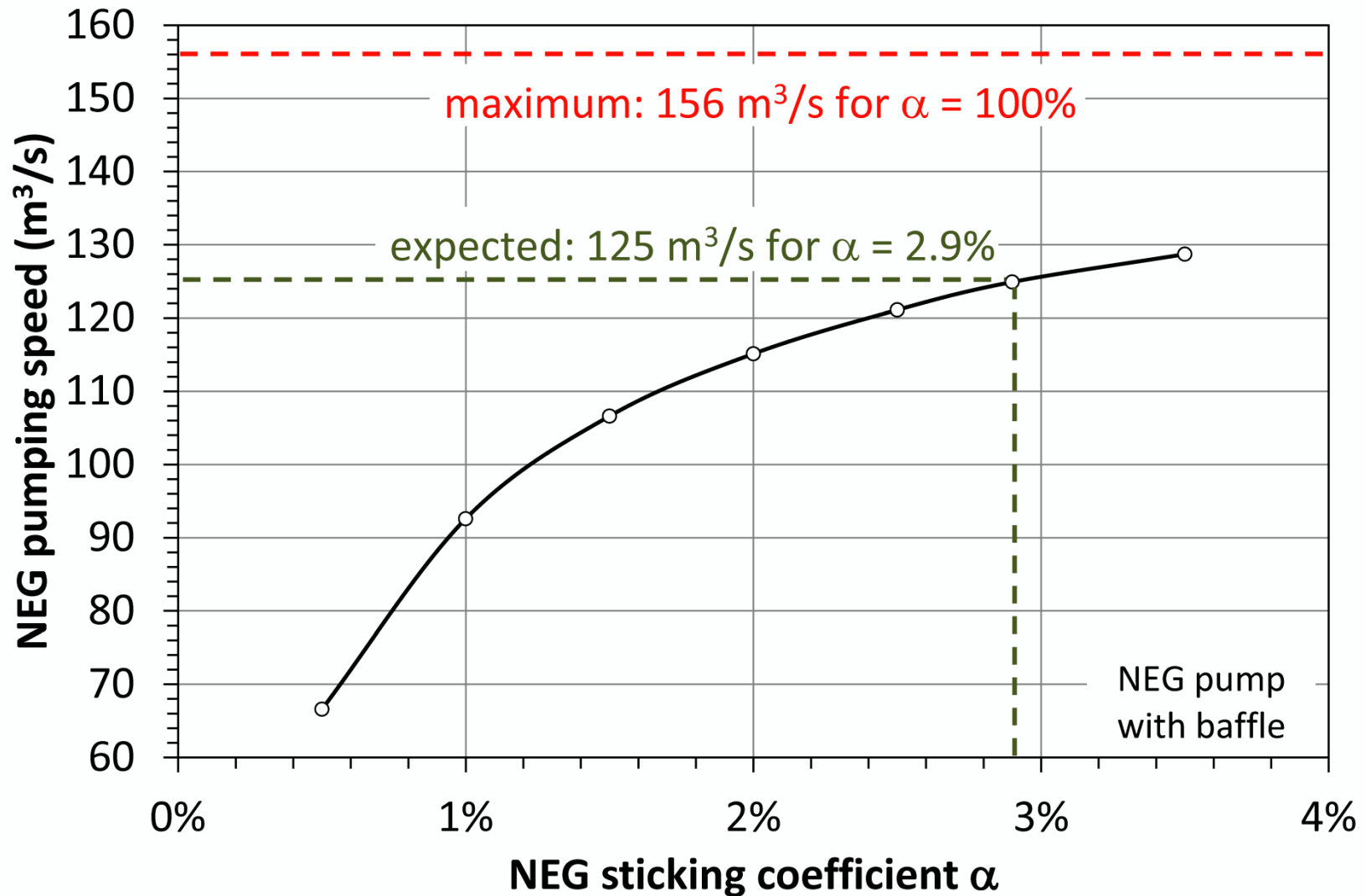

# Simulation results for the NEGAs as primary pumps

- ratio of hit numbers in vacuum gauges  $\approx$  ratio of pressures:  $p_{PP3} / p_{F9}$
- gas: hydrogen

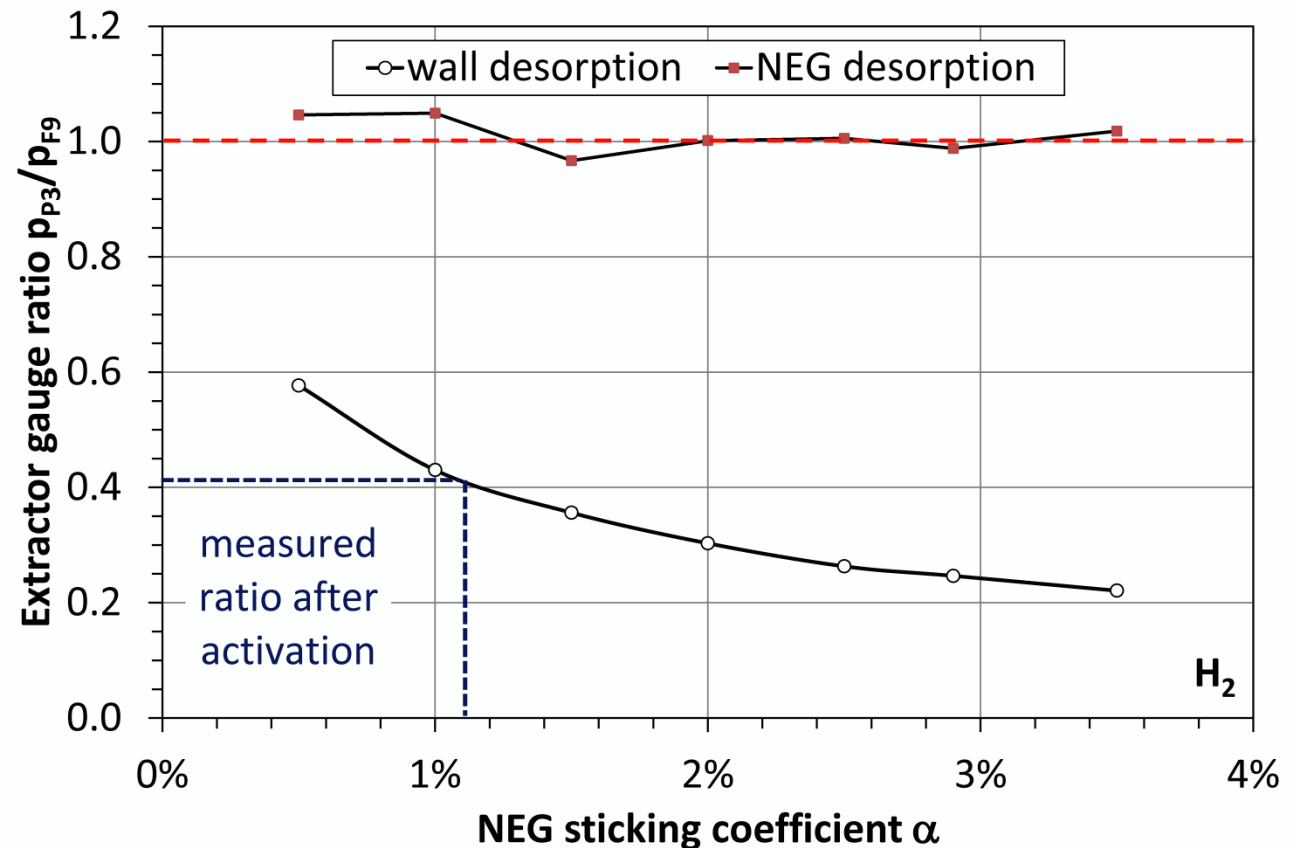
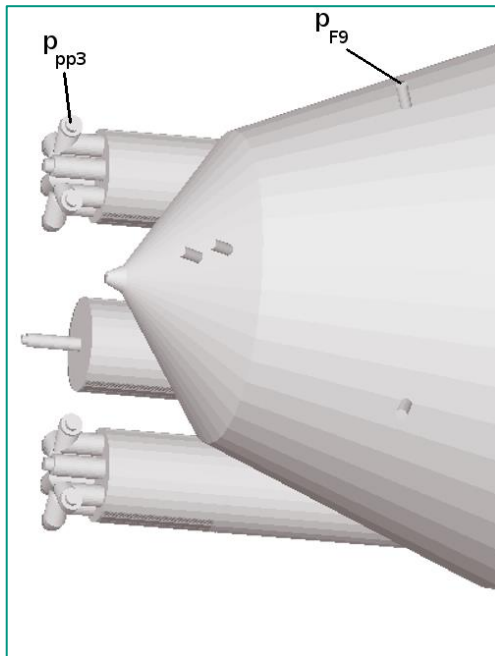

# Simulation results for the NEGAs as primary pumps

- calculation of the NEG pumping speed:  $S = \frac{1}{4} \cdot \bar{c} \cdot A \cdot \frac{N_{\text{NEG}}}{N_{\text{des}}}$
- gas: hydrogen

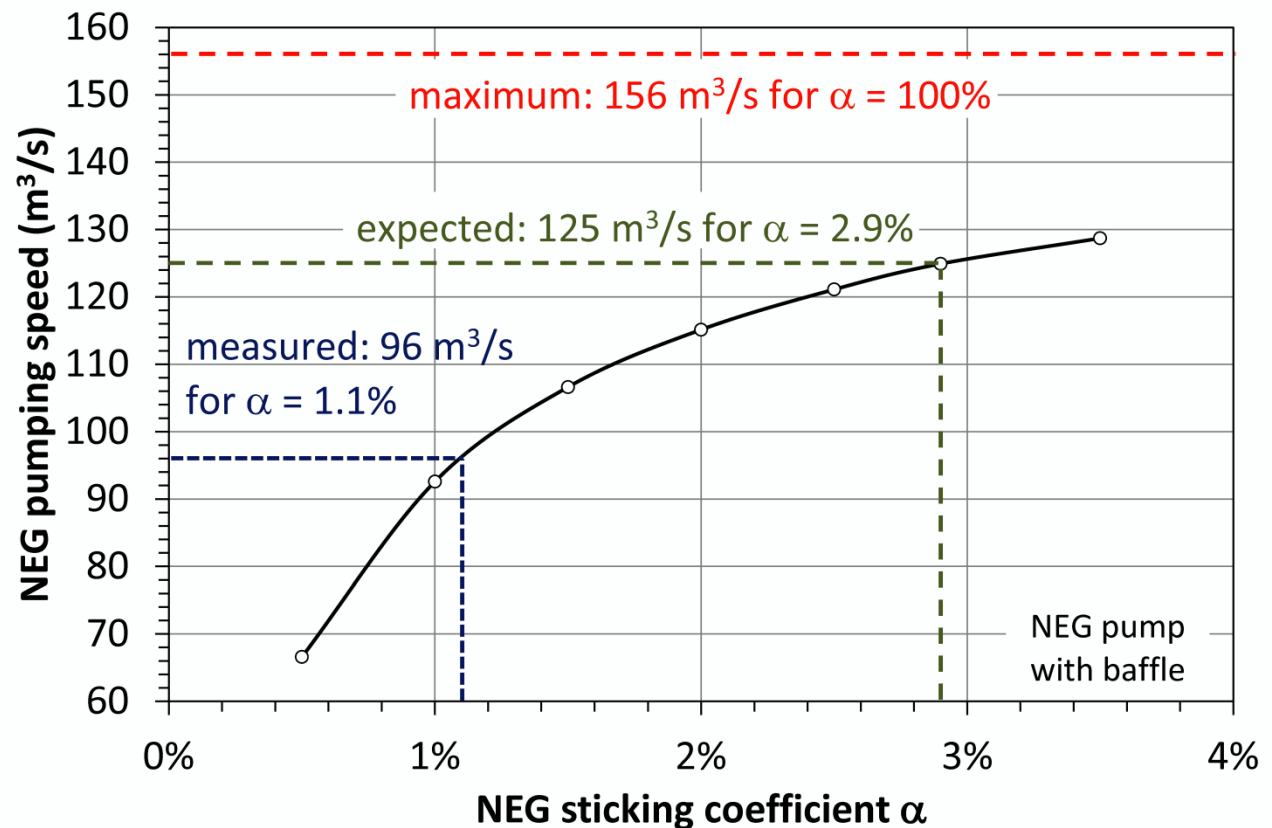
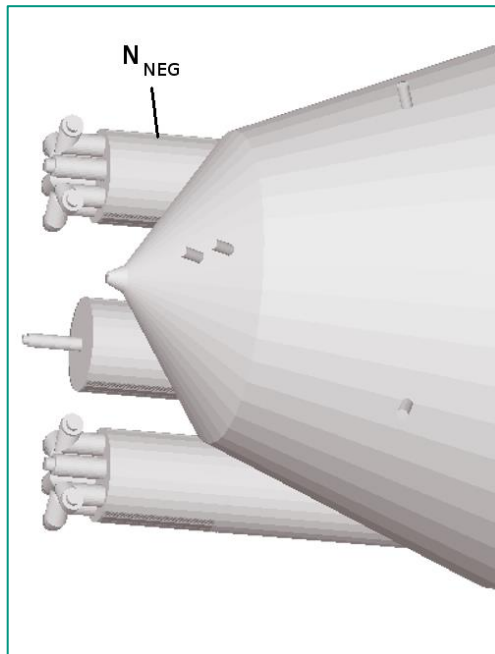



# Simulation results for the TMPs as primary pumps

- ratio of hit numbers in vacuum gauges  $\approx$  ratio of pressures:  $p_{P3} / p_{F9}$
- gas: radon

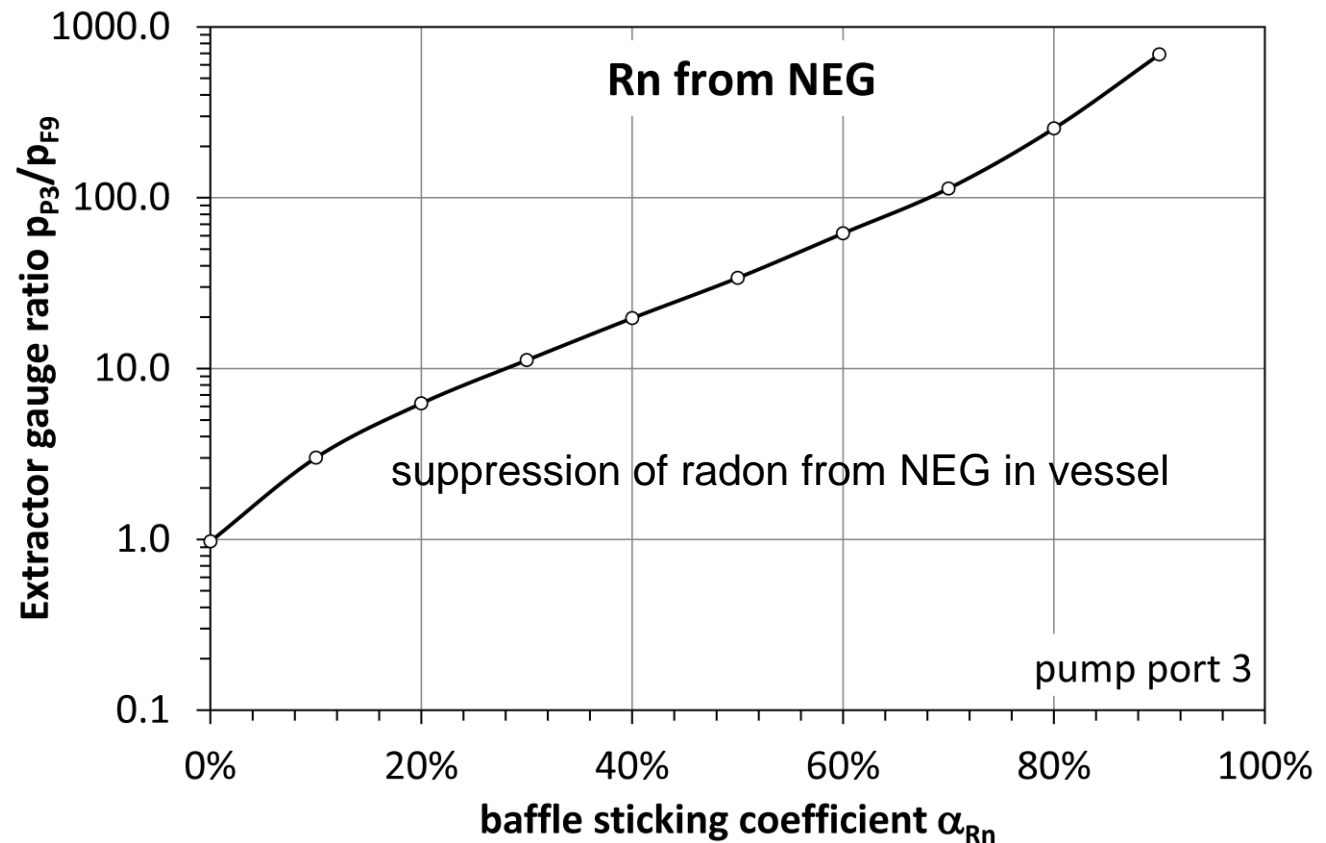
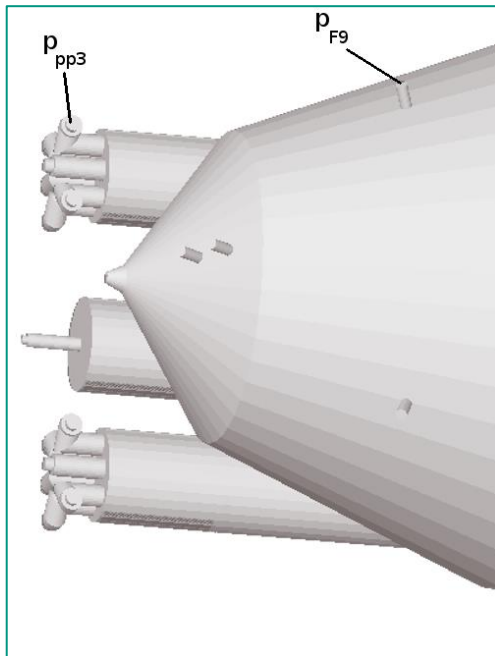

# Simulation results for the TMPs as primary pumps

- calculation of the pumping speed (TMP + Baffle):  $S = \frac{1}{4} \cdot \bar{c} \cdot A \cdot \frac{N_{\text{TMP}} + N_{\text{Baffle}}}{N_{\text{des}}}$
- gas: radon

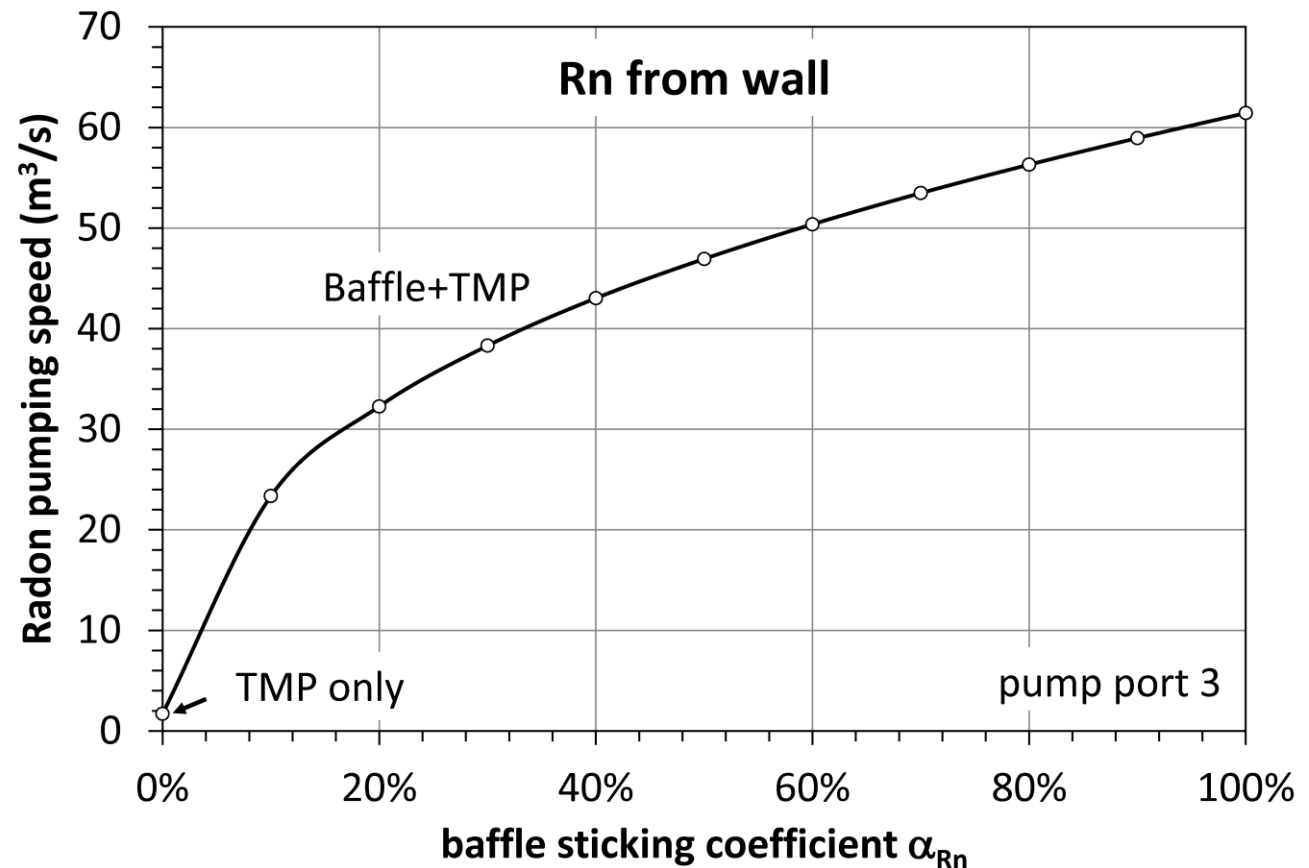
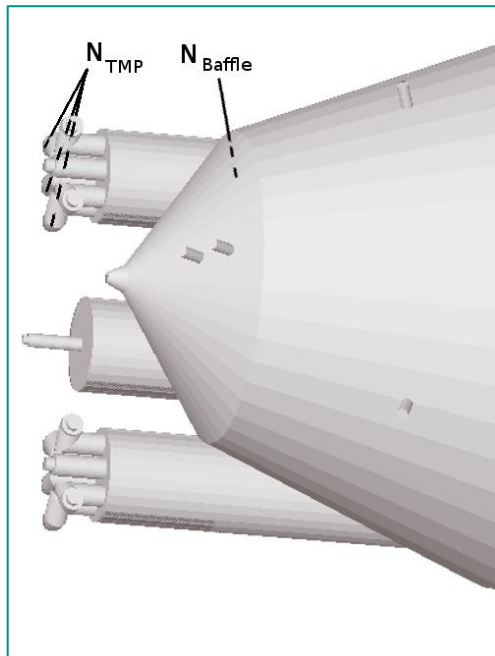

# NEG simulation with baffle (MolFlow+)

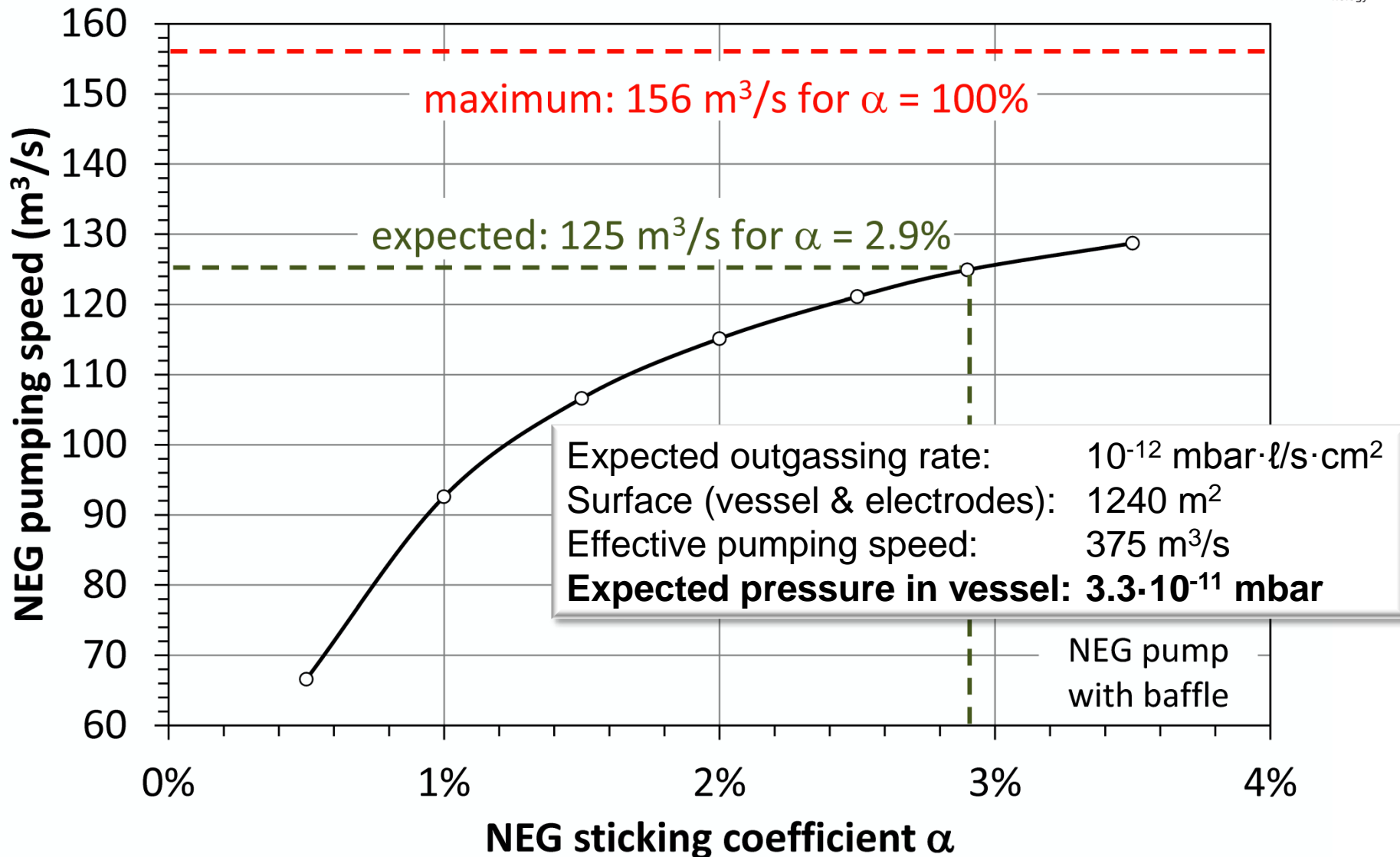

# Baffle simulation for Radon (MolFlow+)

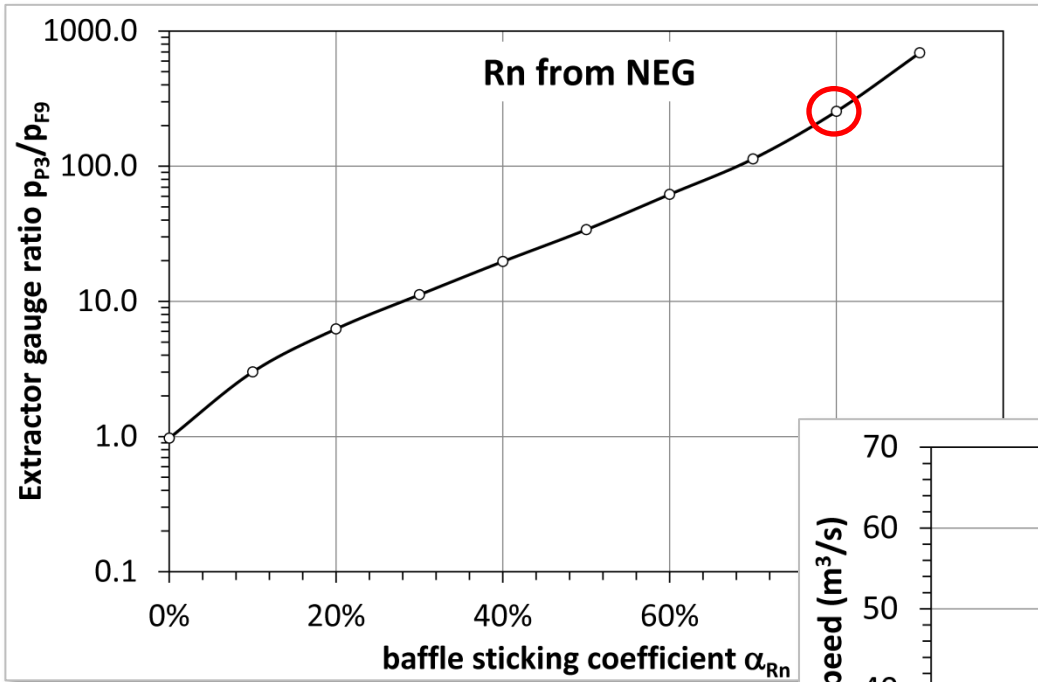

- $\alpha_{Rn} \sim 80\%$  estimated from Pre-Spectrometer results
- **Suppression factor** for radon emanating from NEG:  **$\sim 250$**

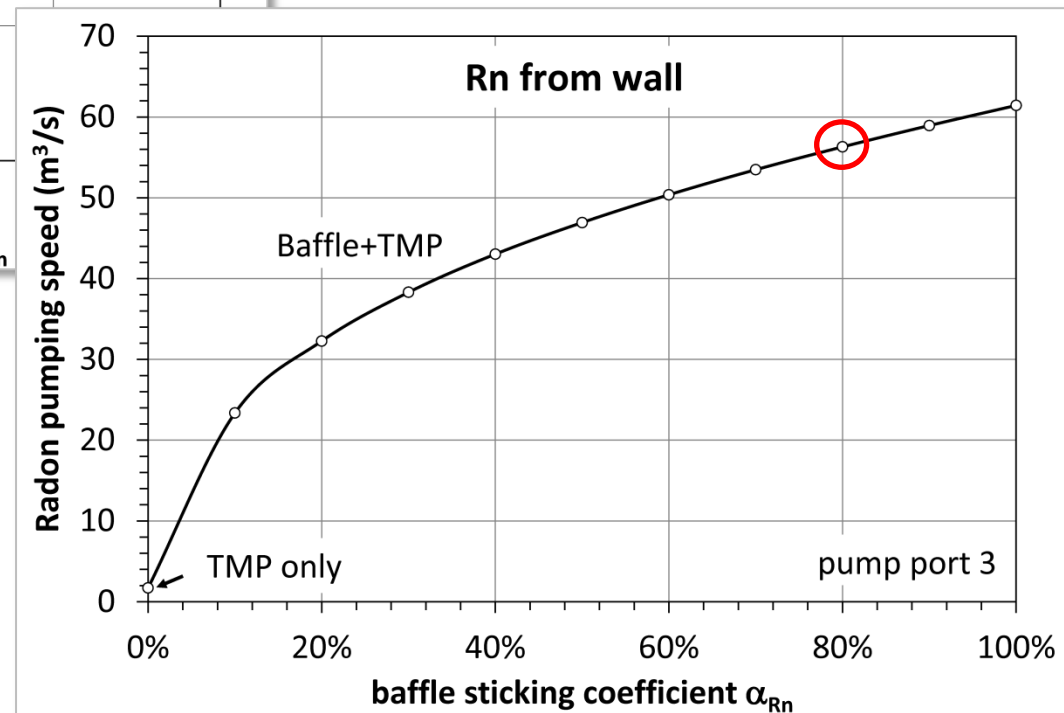

- Effective pumping speed for **6 TMPs: 3400  $\ell/s$**
- Effective pumping speed for **3 baffles:  $\sim 170\,000 \ell/s$**

# Hydrogen outgassing and pressure at 20°C

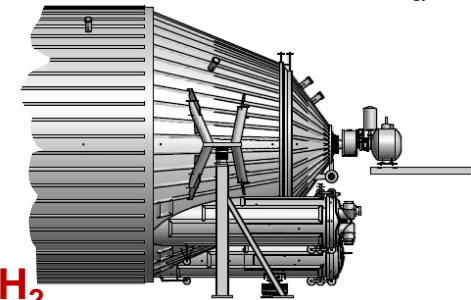

- Fit of  $p_{P3}$  versus  $p_{F9}$ 
  - **NEG pumping speed** from  $p_{P3}/p_{F9}$ : **290 m<sup>3</sup>/s** ( $\alpha = 1.1\%$ )
  - **Offset** of Extractor gauge F9:  **$1.8 \cdot 10^{-10}$  mbar**
- Fit of  $p_{F9} \cdot \sqrt{T/293K}$  versus  $1/T$ 
  - **Desorption enthalpy** of H<sub>2</sub> on st. steel: **53 kJ/mol = 0.55 eV/H<sub>2</sub>**
  - Extrapolated **pressure at 20°C**:  **$2.6 \cdot 10^{-11}$  mbar** (gas corr. H<sub>2</sub>:  **$5.7 \cdot 10^{-11}$  mbar**)
- **Outgassing rate**  $j_{H_2} = p(20^\circ C) \cdot S_{eff}/A = 1.4 \cdot 10^{-12}$  mbar·ℓ/s·cm<sup>2</sup>

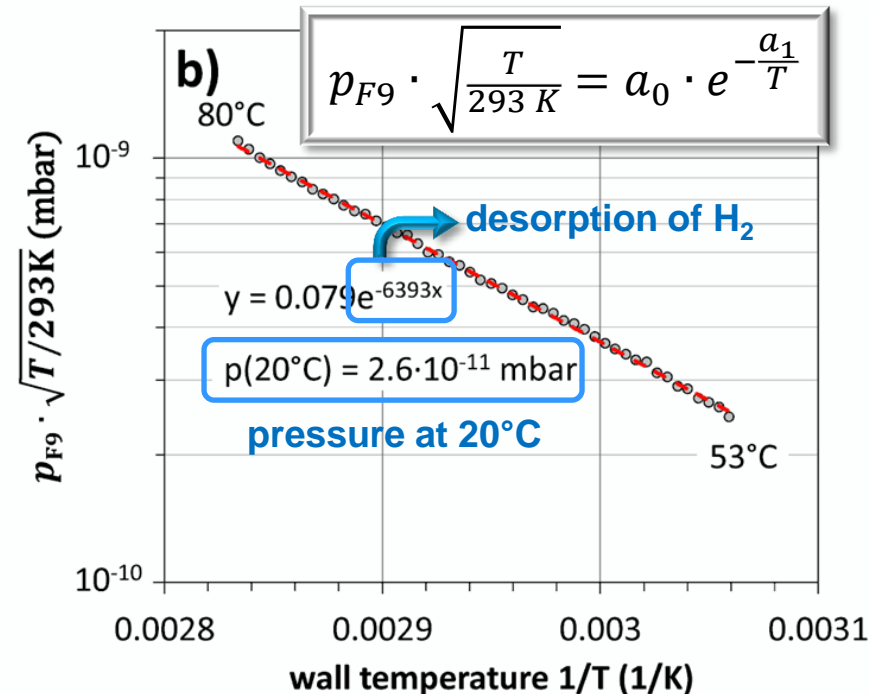
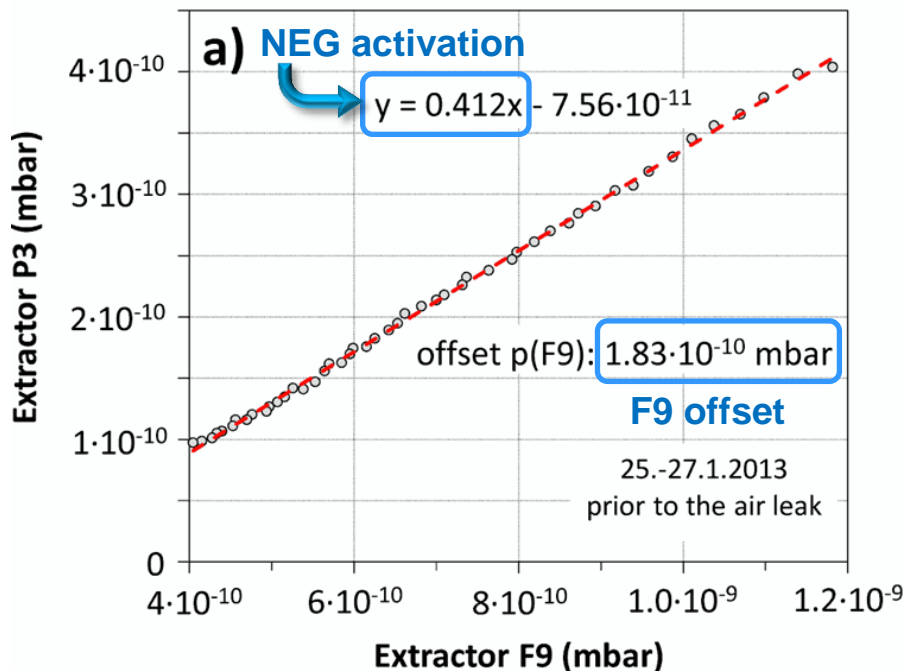

# Vacuum status with cold baffles

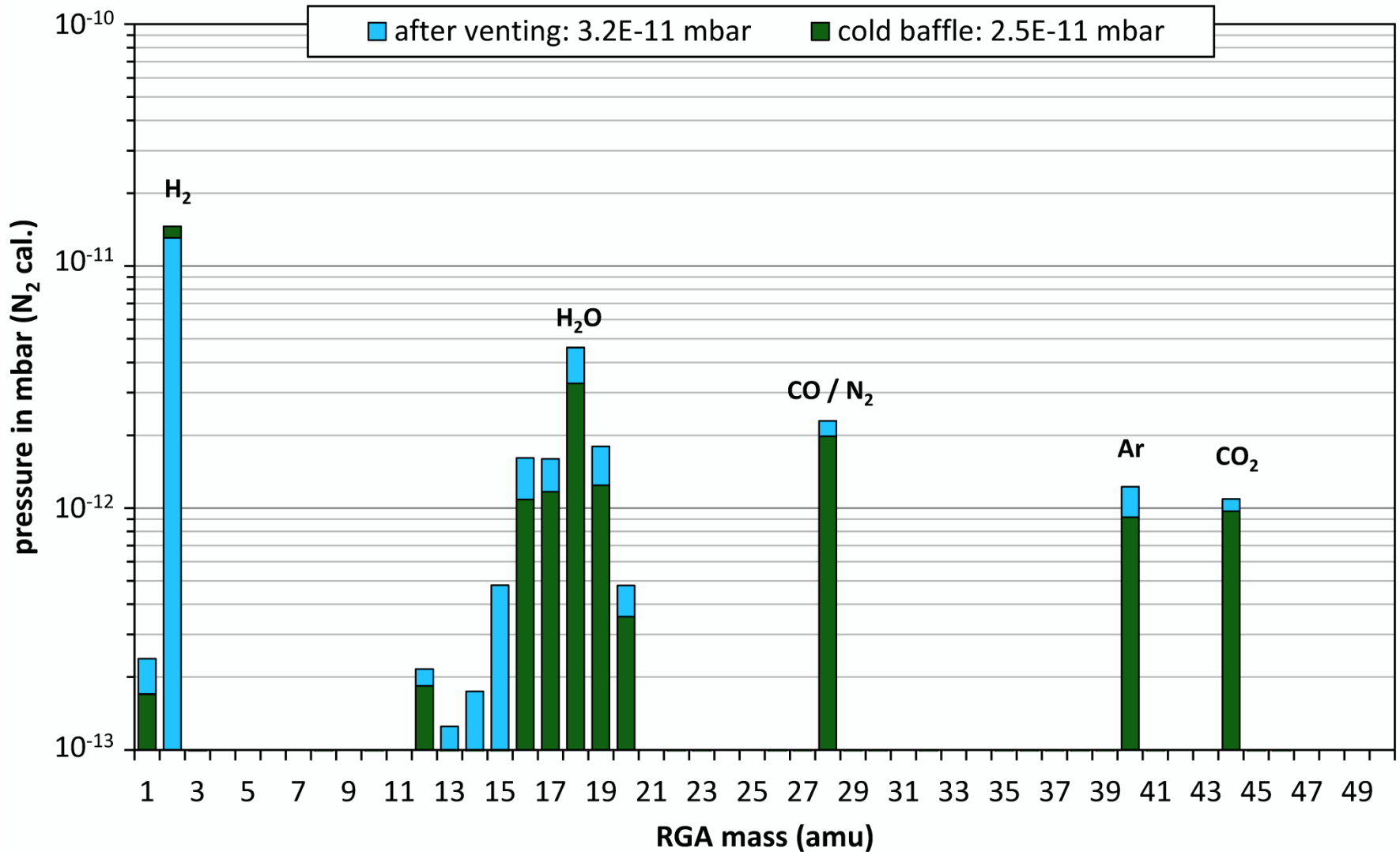

# RGA spectrum (all)

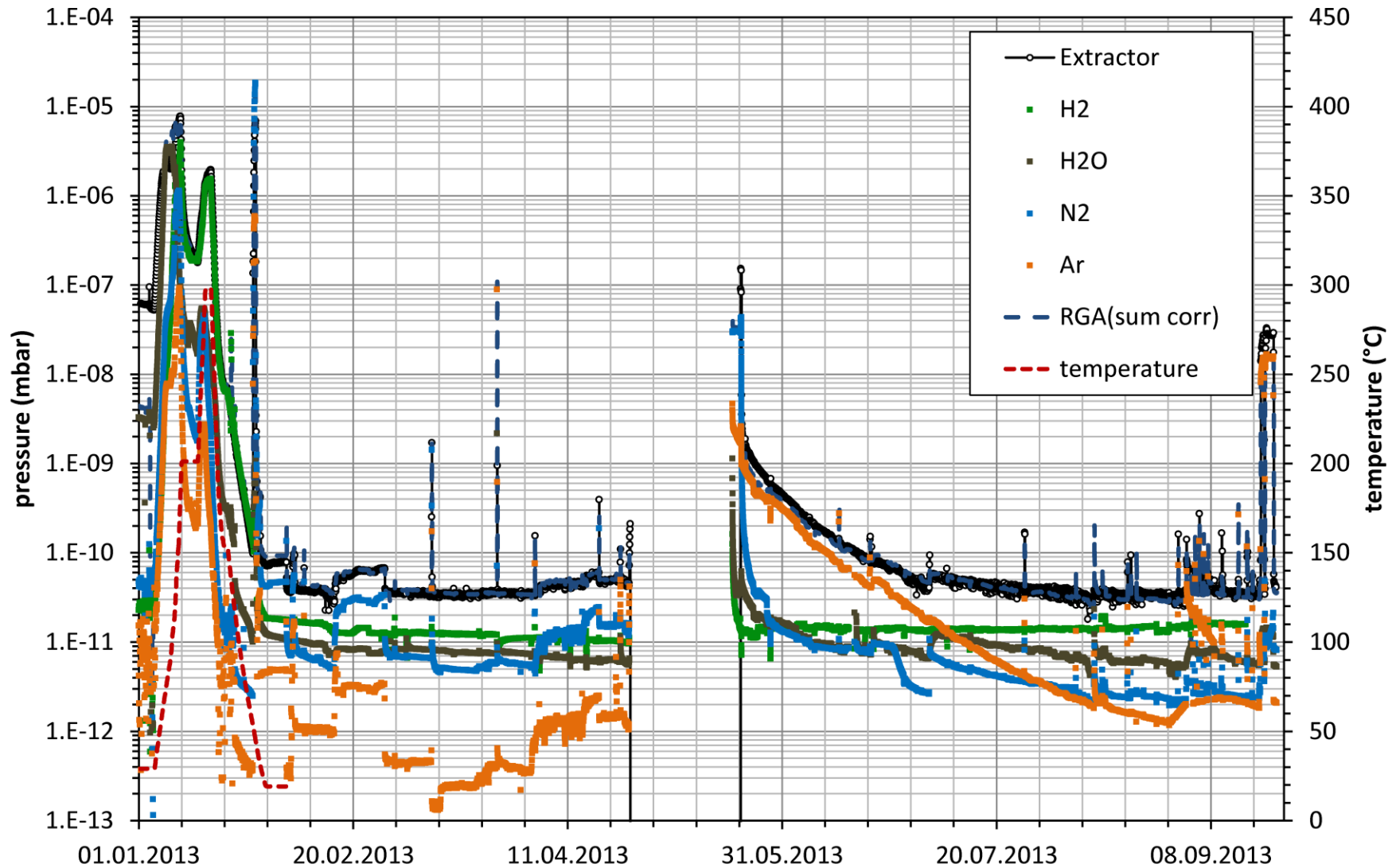

# RGA spectrum after venting

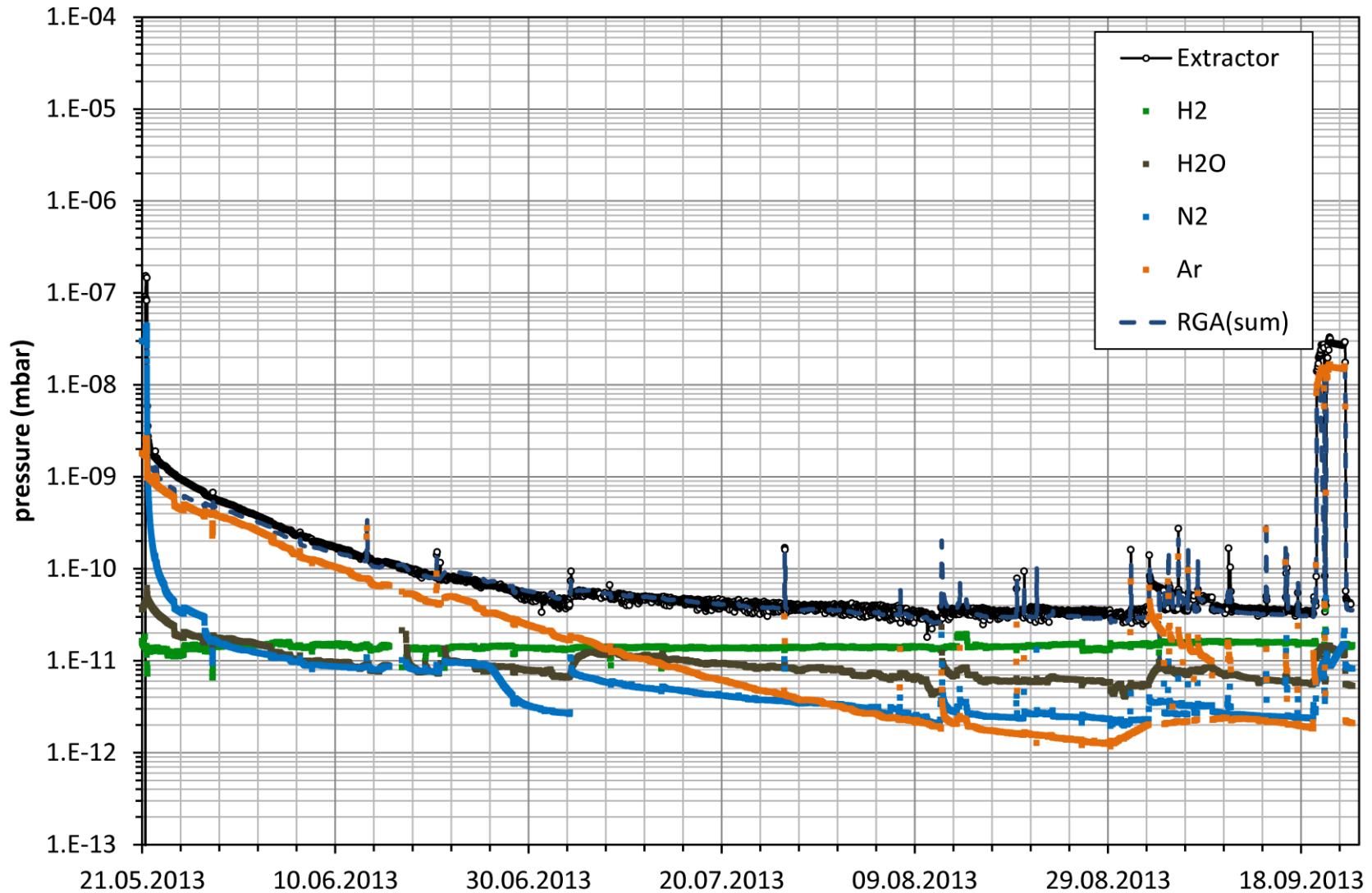



# KATRIN Main Detector

- Si-PIN diode
- detection of transmitted  $\beta$ 's (mHz to kHz)
- **low background for  $T_2$  endpoint investigation**
- high energy resolution:  
 $\Delta E = 1.48(1)$  keV (FWHM) at 18.6 keV
- 12 rings with  $30^\circ$  segmentation + 4-fold center = 148 pixels
  - minimize bg, investigate systematic effects
  - compensate field inhomogeneities of spectrometer's analyzing plane.

